

Item Number	Document Number	Title	Quantity	Item Number	Document Number	Title	Quantity
1	M6-20	Cap Screw	8	8	PV150-0084	Outer Spring	1
2	P2-029	O-Ring	2	9	PV150-0085	Inner Spring	1
3	P2-127	O-Ring	2	10	PV150-0088	H R Std Spring Cup	2
4	P2-212	O-Ring	2	11	PV150-0090	H R Spool Sealing Washer	2
5	PV150-0010	Std Housing V150	1	12	PV150-0091	H R Std Positioner Bolt	2
6	PV150-0020	Std Spool	1	13	PV150-0094	H R Std Positioner Bush	1
7	PV150-0080	Hyd Rem Bonnet Die Cast	2	14	PWS-6	Spring Washer	8

REVISION HISTORY			
REV	DESCRIPTION	DATE	APPROVED

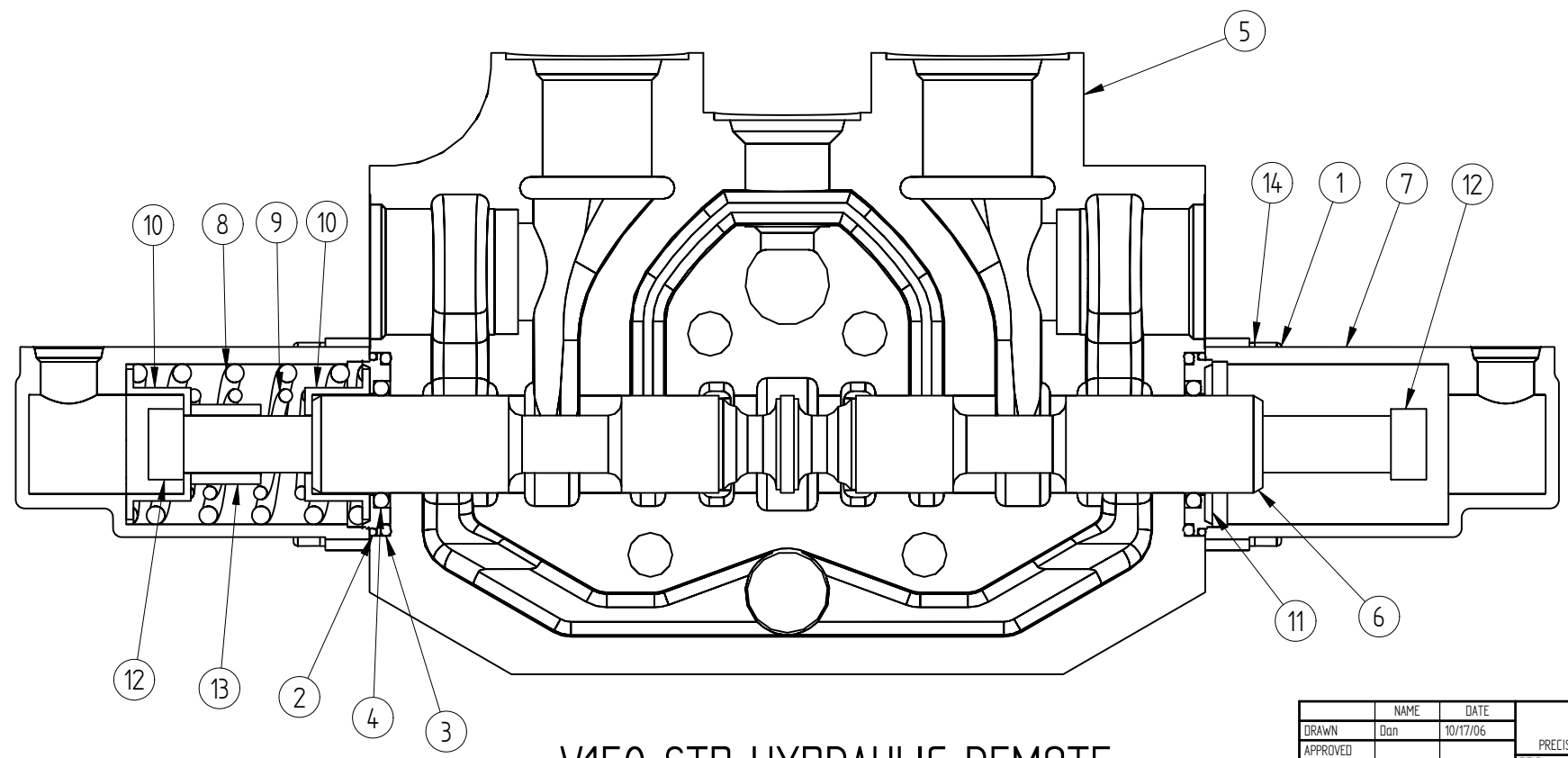

V150 STD HYDRAULIC REMOTE

NAME	DATE	PREMAC	
DRAWN Dan	10/17/06	PRECISION MACHINE MANUFACTURERS (PTY)LTD.	
APPROVED		TITLE	
MATERIAL		V150 Std Hyd Rem	
TREATMENT		SIZE A2	DWG NO
UNLESS OTHERWISE SPECIFIED DIMENSIONS ARE IN MILLIMETERS ANGLES ±0.1°		FILE NAME: Std Hyd Rem.dft	REV
2 PL ±0.02	3 PL ±0.005	SCALE:	WEIGHT:
		SHEET 1 OF 1	

Item Number	Document Number	Title	Quantity	Item Number	Document Number	Title	Quantity
1	Ø18-2.5-2	Copper Washer	2	13	PV150-0083	Bonnet End Cap Spool Limiter	2
2	M6-100	Cap Screw	8	14	PV150-0084	Outer Spring	1
3	M6-12	Countersink Screw	2	15	PV150-0085	Inner Spring	1
4	P2-012	O-Ring	2	16	PV150-0088	H R Std Spring Cup	2
5	P2-029	O-Ring	2	17	PV150-0090	H R Spool Sealing Washer	2
6	P2-124	O-Ring	2	18	PV150-0091	H R Std Positioner Bolt	2
7	P2-127	O-Ring	2	19	PV150-0094	H R Std Positioner Bush	1
8	P2-212	O-Ring	2	20	PV150-0097	Spool Limiter Body	2
9	P8-012	Back Up	2	21	PV150-0098	Adjuster Screw	2
10	PV150-0010	Std Housing V150	1	22	PV150-0099	Adjuster Screw Stopper	2
11	PV150-0020	Std Spool	1	23	PWS-6	Spring Washer	8
12	PV150-0081	Hyd Rem Bonnet Cut Off	2				

REVISION HISTORY			
REV	DESCRIPTION	DATE	APPROVED

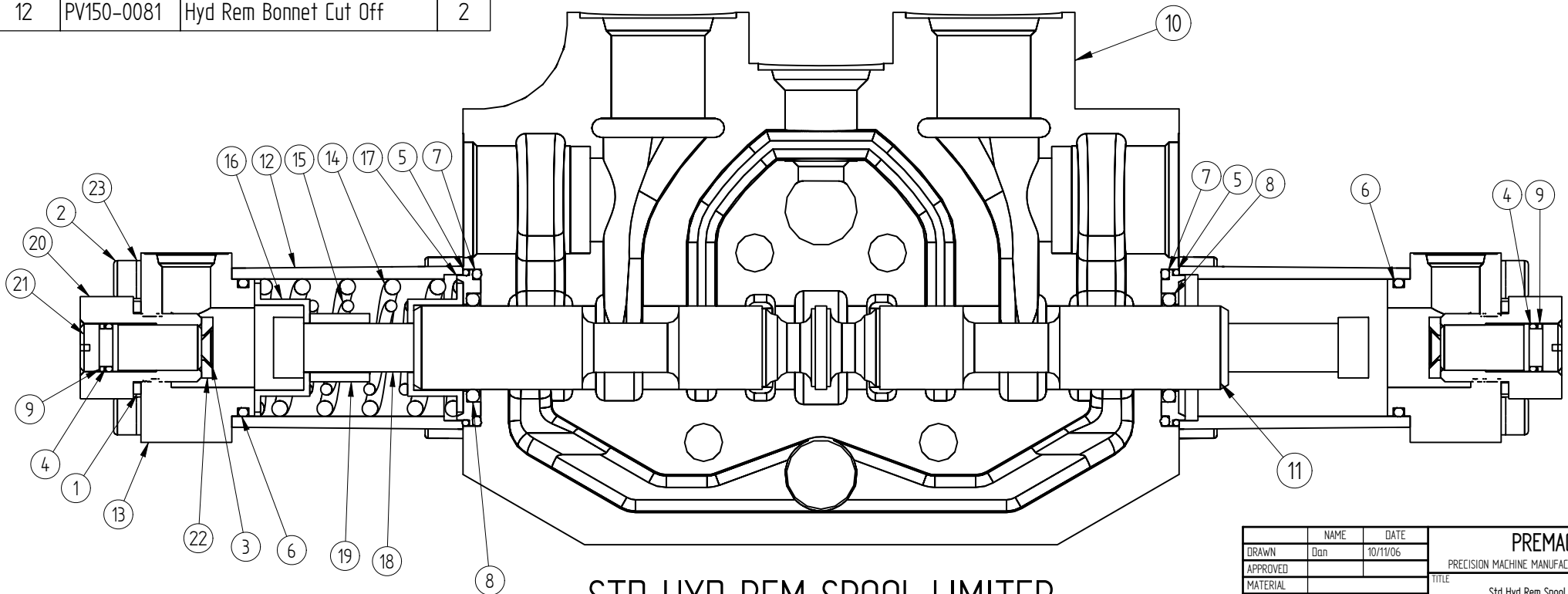

STD HYD REM SPOOL LIMITER

DRAWN	NAME	DATE	PREMAC	
APPROVED	Dan	10/11/06	PRECISION MACHINE MANUFACTURERS (PTY)LTD.	
MATERIAL			TITLE	
TREATMENT			Std Hyd Rem Spool Limiter	
UNLESS OTHERWISE SPECIFIED DIMENSIONS ARE IN MILLIMETERS ANGLES ±0.1°			SIZE	DWG NO
2 PL ±0.02 3 PL ±0.005			A2	
FILE NAME: Std Hyd Rem Spool Limiter.dft			SCALE	WEIGHT
				SHEET 1 OF 1

Item Number	Document Number	Title	Quantity	Item Number	Document Number	Title	Quantity
1	P2-029	O-Ring	2	9	PV150-0086	H R Float Washer	1
2	P2-124	O-Ring	2	10	PV150-0087	H R Float Inner Spring	2
3	P2-127	O-Ring	3	11	PV150-0089	H R Float Spring Cup	2
4	P2-212	O-Ring	2	12	PV150-0090	H R Spool Sealing Washer	2
5	PV150-0010	Std Housing V150	1	13	PV150-0092	H R Float A Positioner Bolt	1
6	PV150-0021	Float Spool	1	14	PV150-0093	Std Hyd Rem Spool Limiter	1
7	PV150-0081	Hyd Rem Bonnet Cut Off	2	15	PV150-0095	H R Float Washer	2
8	PV150-0082	Bonnet End Cap	2	16	PV150-0096	H R Spool Sealing Washer	1

REVISION HISTORY			
REV	DESCRIPTION	DATE	APPROVED

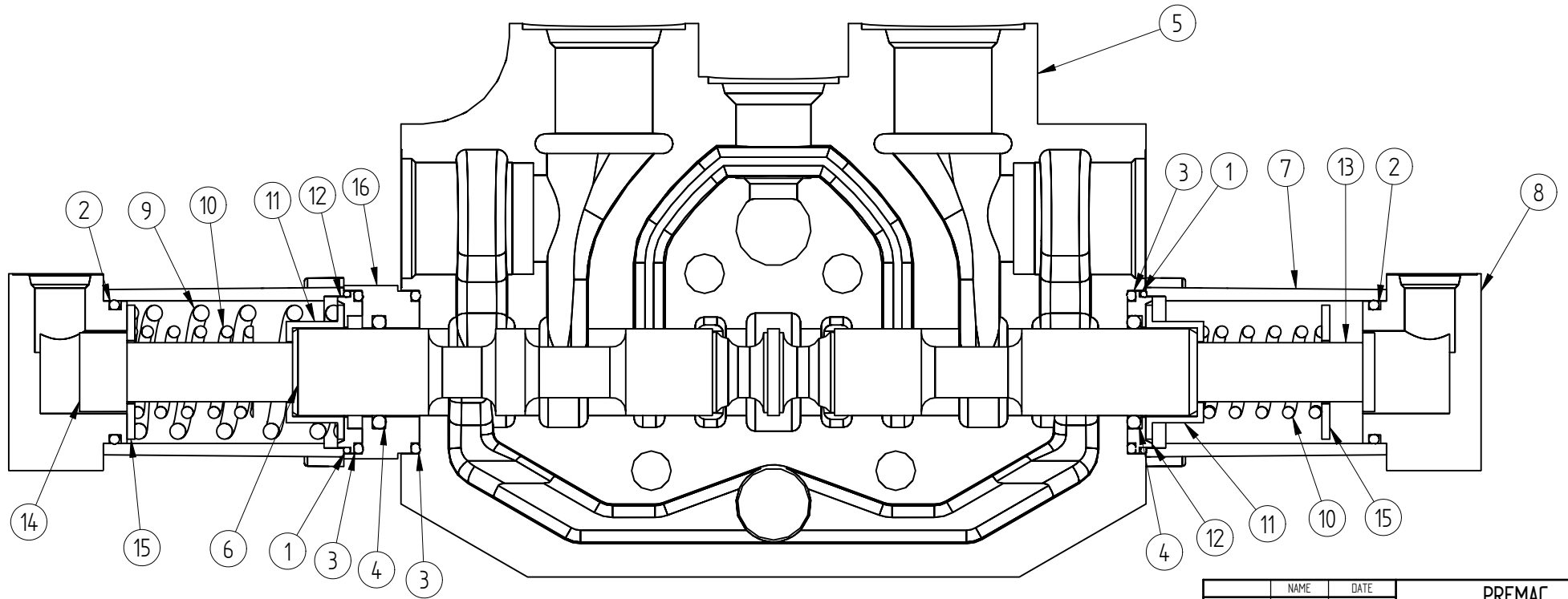

FLOAT HYDAULIC REMOTE

NAME	DATE	PREMAC	
DRAWN Dan	10/17/06	PRECISION MACHINE MANUFACTURERS (PTY)LTD.	
APPROVED		TITLE	
MATERIAL		Float Hyd Remote	
TREATMENT			
UNLESS OTHERWISE SPECIFIED DIMENSIONS ARE IN MILLIMETERS ANGLES ±0.1°		SIZE A2	DWG NO
2 PL ±0.02 3 PL ±0.005		FILE NAME: Float Hyd Remote.dft	REV
SCALE	WEIGHT	SHEET 1 OF 1	