

REVISION HISTORY

REV	DESCRIPTION	DATE	APPROVED

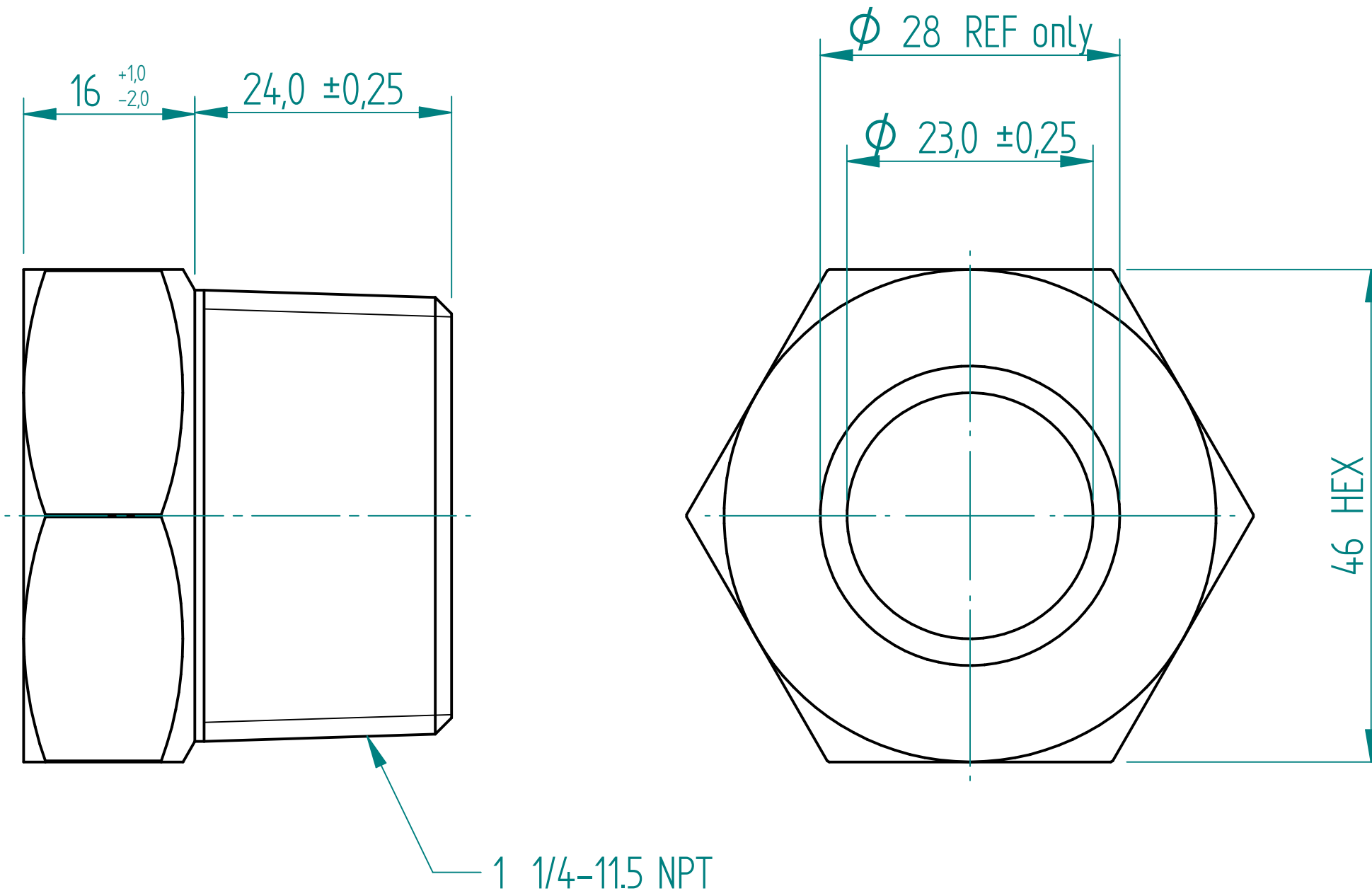

DRAWN		NAME	DATE	PREMAC TITLE 1.1/4 NPT SIGHT GLASS	
APPROVED		Dan	07/03/1998		
MATERIAL		D.L.G.	07/03/1998		
TREATMENT		STEEL			
		PLATING		SIZE	DWG NO
UNLESS OTHERWISE SPECIFIED DIMENSIONS ARE IN MILLIMETERS 1 st ANGLE ANGLES ±0.1° 2 PL ±0.02 3 PL ±0.005				A4	1.25NPT-FSG
				FILE NAME: NPT-FSG.dft	REV
				SCALE:	WEIGHT:
				SHEET 1 OF 1	