

REVISION HISTORY			
REV	DESCRIPTION	DATE	APPROVED

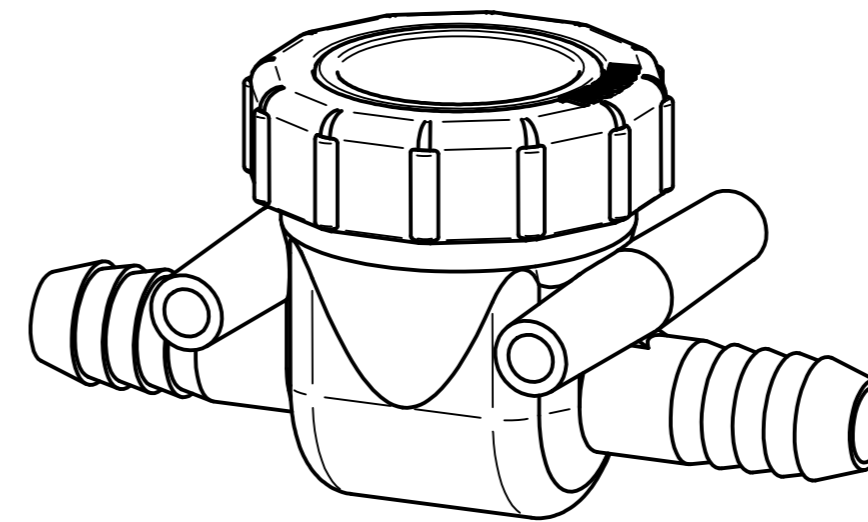

DRAWN	NAME	DATE	AGRIGEL		
APPROVED	Dan	04/29/10			
MATERIAL			TITLE		
TREATMENT			Impeller Monitor		
UNLESS OTHERWISE SPECIFIED DIMENSIONS ARE IN MILLIMETERS			SIZE	DWG NO	REV
1 st ANGLE ANGLES ±0.1°			A4		
2 PL ±0.02 3 PL ±0.005			FILE NAME: Impeller Monitor.dft		
SCALE:		WEIGHT:		SHEET 1 OF 6	

REVISION HISTORY			
REV	DESCRIPTION	DATE	APPROVED

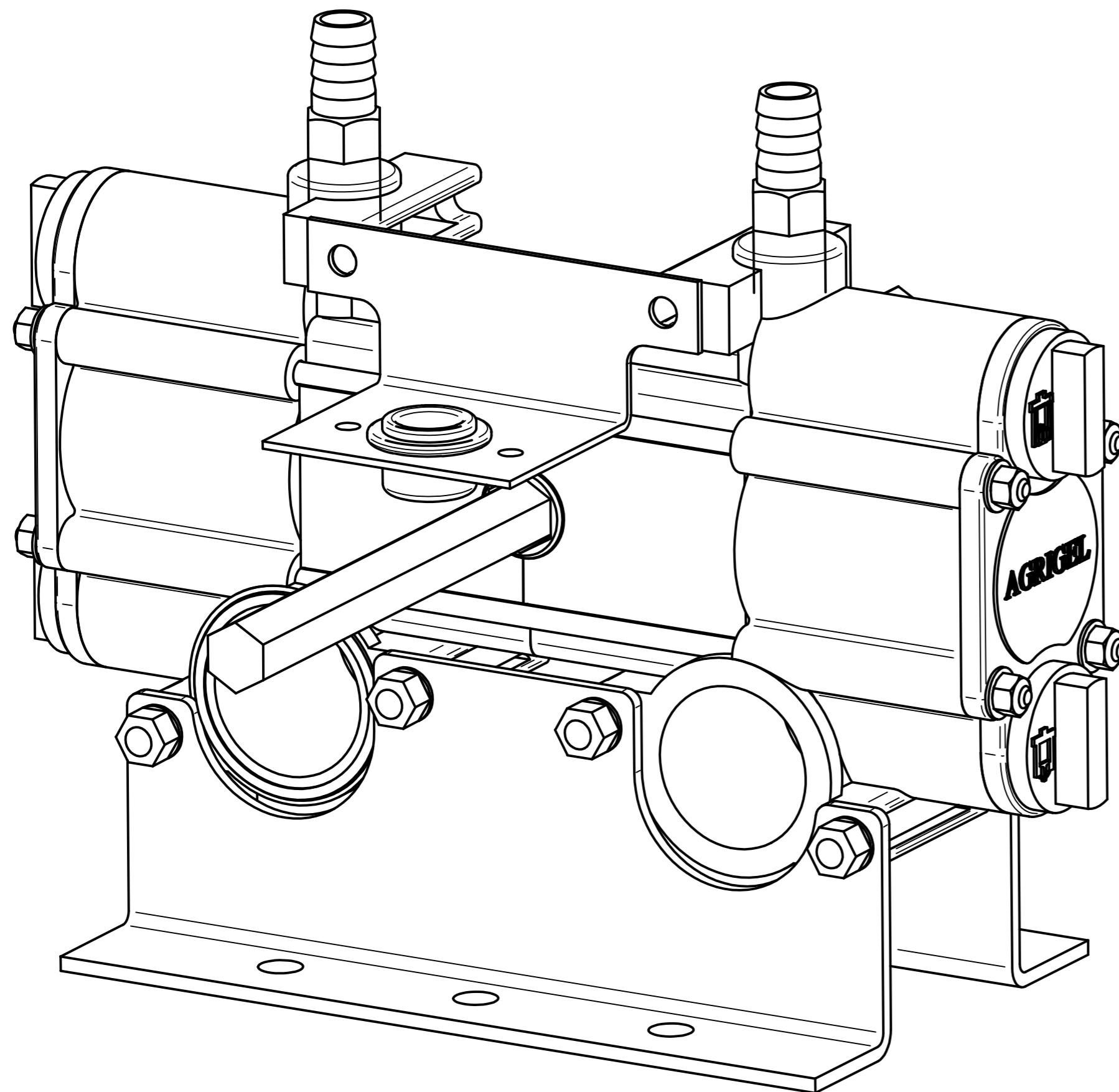
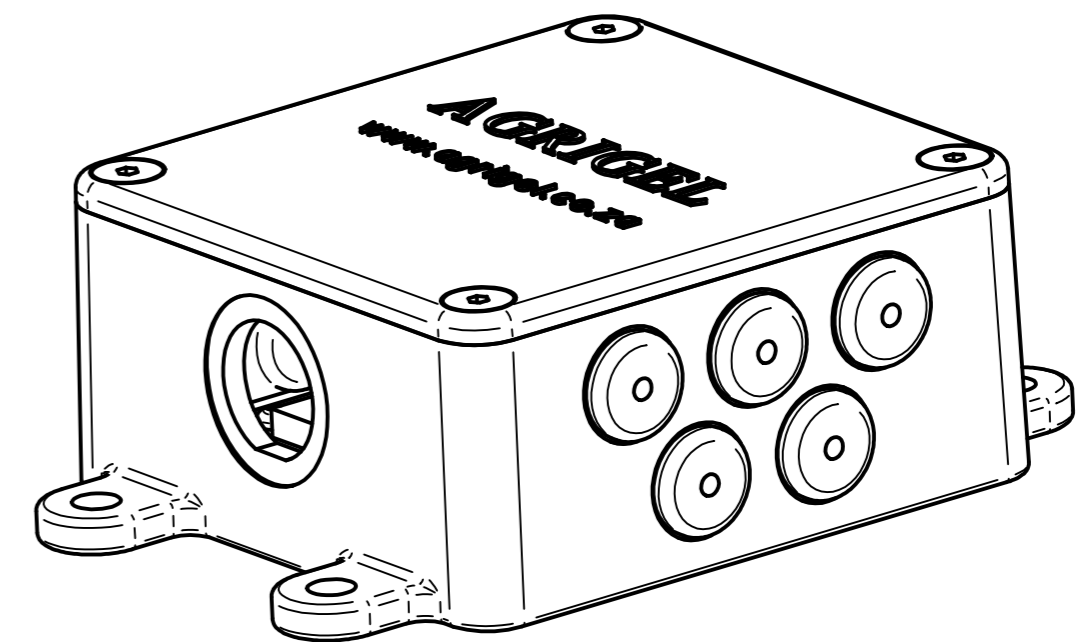
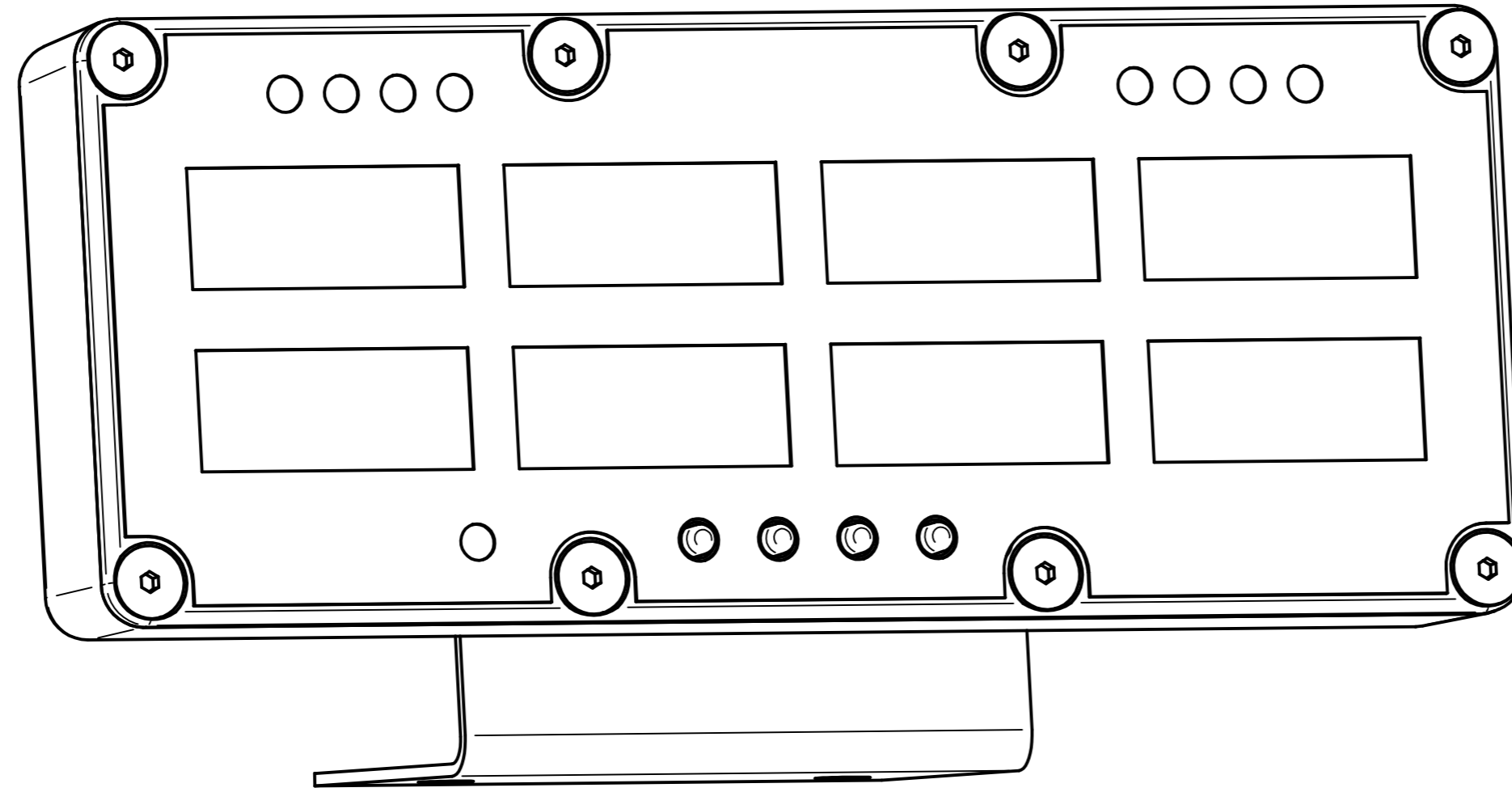
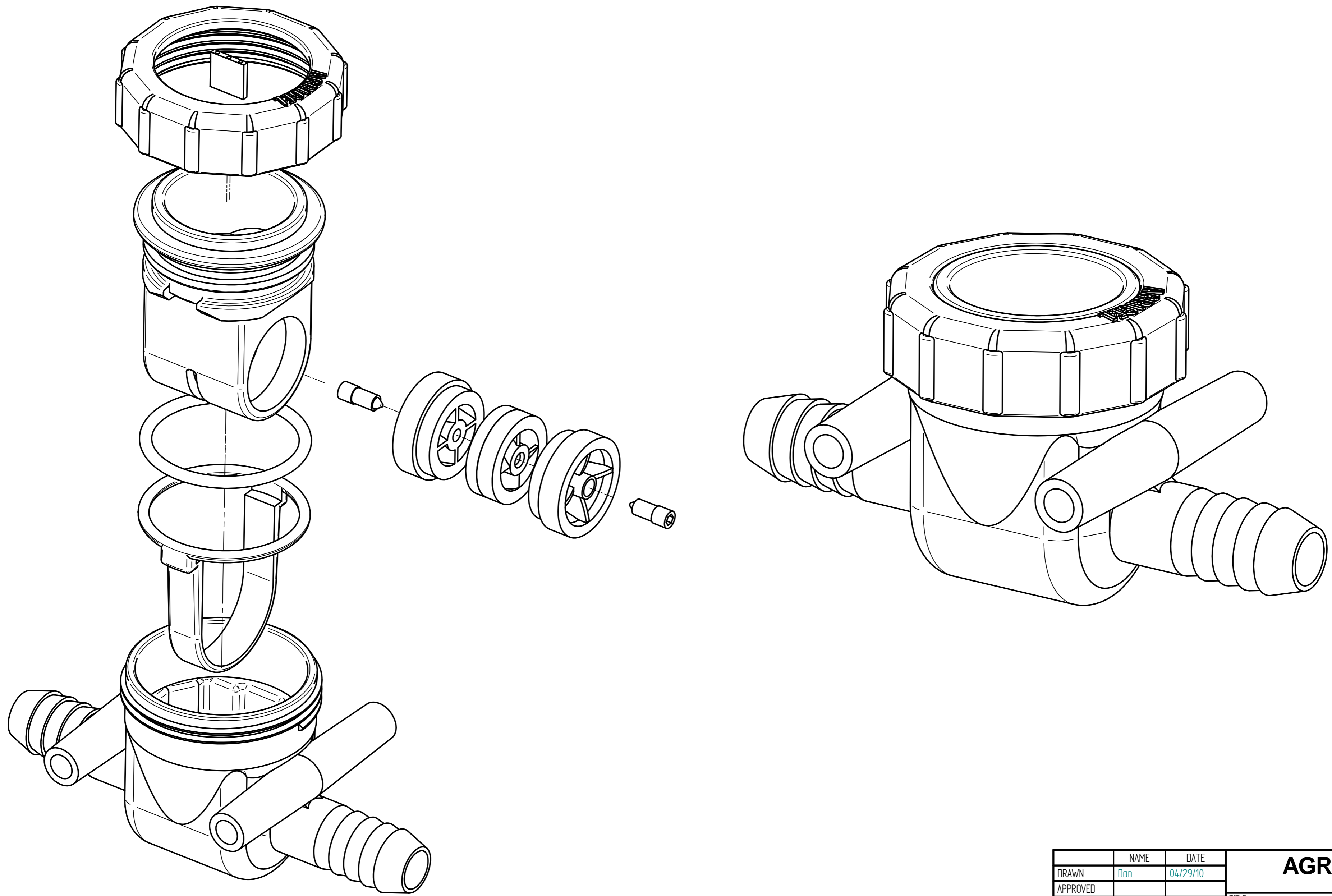

DRAWN	NAME	DATE	AGRIGEL		
APPROVED	Dan	04/29/10			
MATERIAL					TITLE
TREATMENT					Impeller Monitor
UNLESS OTHERWISE SPECIFIED DIMENSIONS ARE IN MILLIMETERS			SIZE	DWG NO	REV
1st ANGLE ANGLES ±0.1°			A4		
2 PL ±0.02 3 PL ±0.005			FILE NAME: Impeller Monitor.dft		
SCALE:		WEIGHT:	SHEET 2 OF 6		

REVISION HISTORY			
REV	DESCRIPTION	DATE	APPROVED

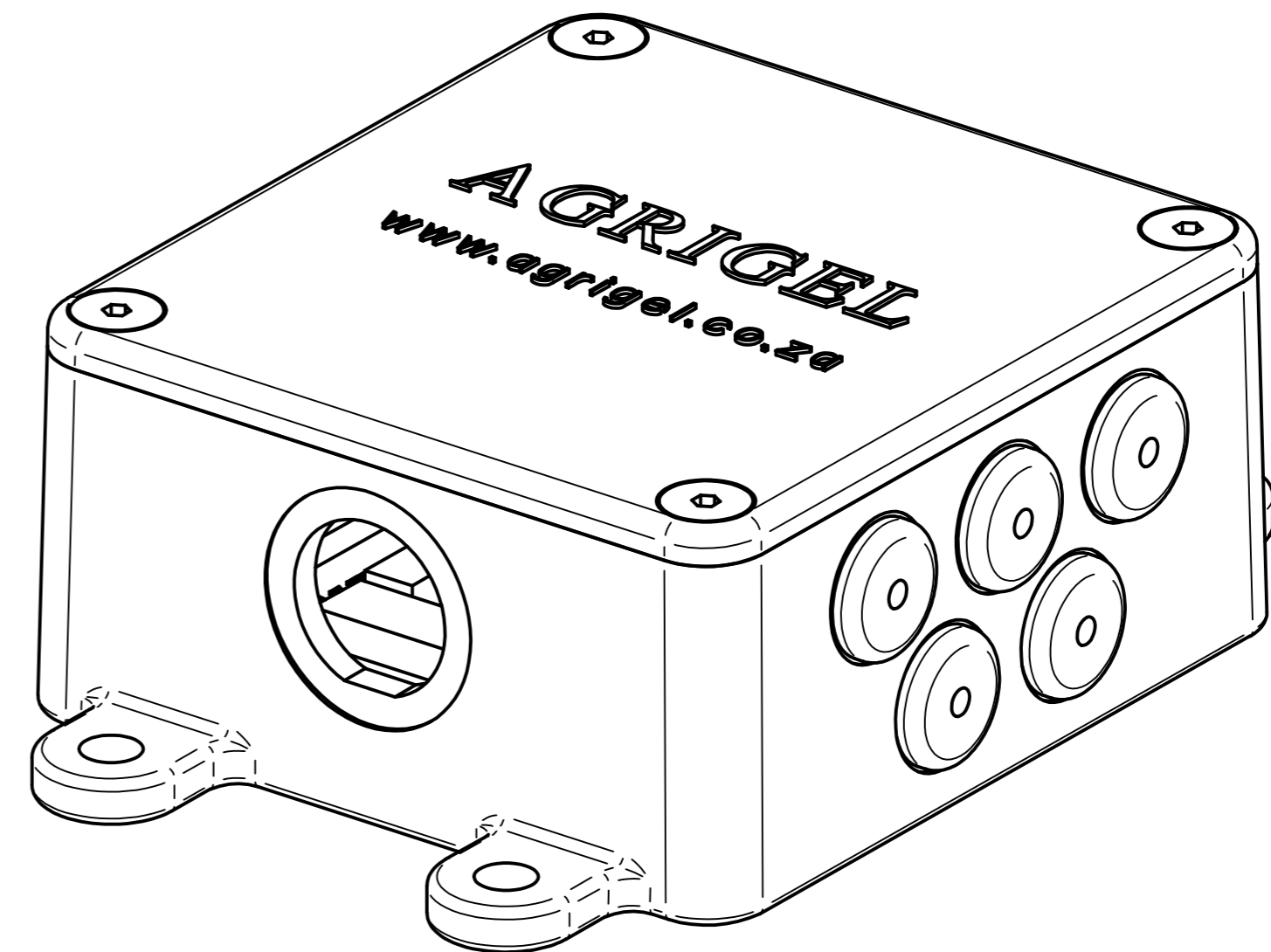
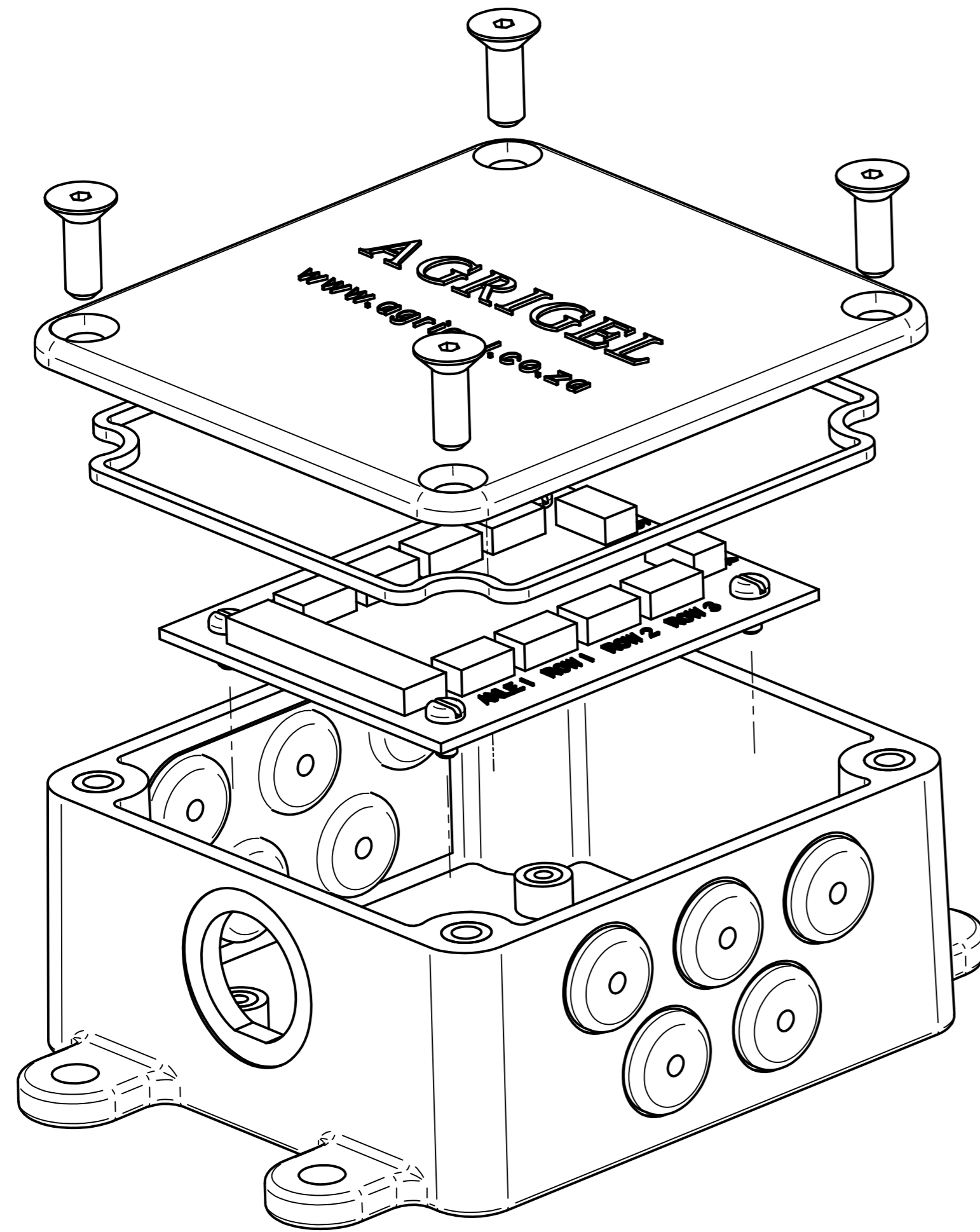

	NAME	DATE	AGRIGEL	
DRAWN	Dan	04/29/10		
APPROVED				
MATERIAL				
TREATMENT			TITLE	Impeller Monitor
UNLESS OTHERWISE SPECIFIED DIMENSIONS ARE IN MILLIMETERS			SIZE	DWG NO
1st ANGLE ANGLES ±0.1°			A4	
2 PL ±0.02 3 PL ±0.005			FILE NAME: Impeller Monitor.dft	REV
			SCALE:	WEIGHT:
			SHEET 3 OF 6	

REVISION HISTORY			
REV	DESCRIPTION	DATE	APPROVED

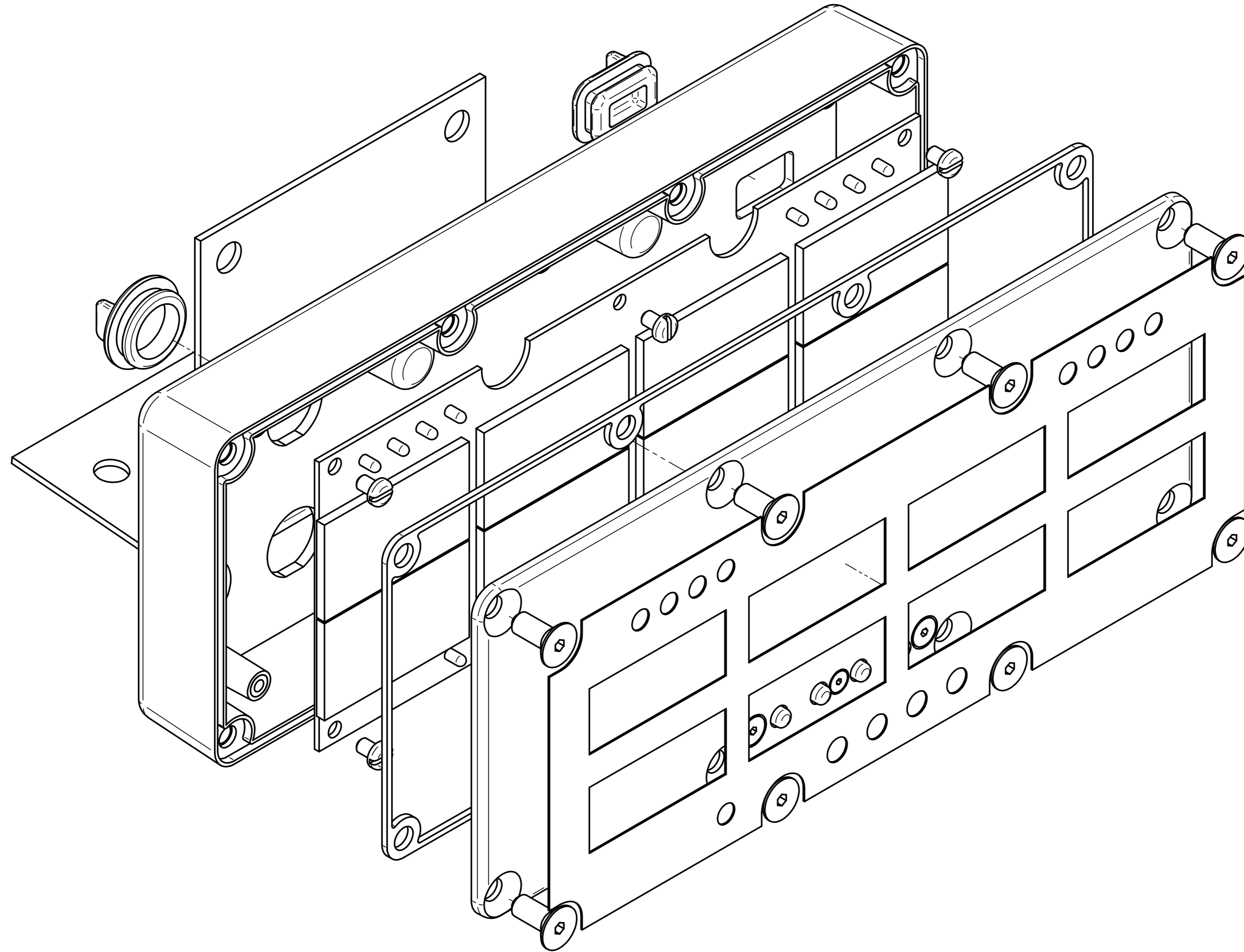

	NAME	DATE	AGRIGEL		
DRAWN	Dan	04/29/10			
APPROVED					
MATERIAL					
TREATMENT			TITLE	Impeller Monitor	
UNLESS OTHERWISE SPECIFIED DIMENSIONS ARE IN MILLIMETERS			SIZE	DWG NO	REV
ANGLES ±0.1°			A4		
1st ANGLE			FILE NAME: Impeller Monitor.dft		
2 PL ±0.02 3 PL ±0.005			SCALE:	WEIGHT:	SHEET 4 OF 6

REVISION HISTORY			
REV	DESCRIPTION	DATE	APPROVED

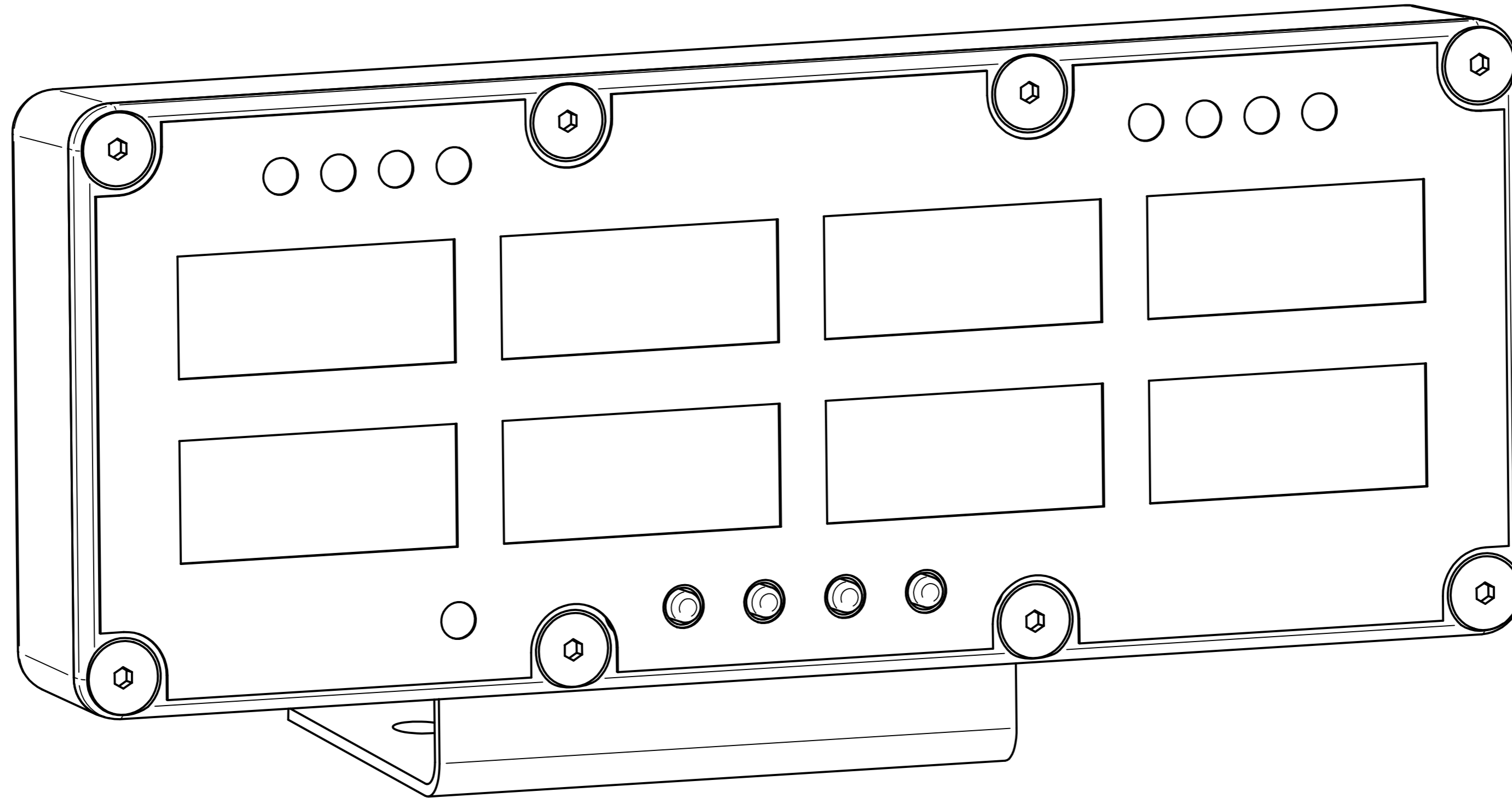

	NAME	DATE	AGRIGEL		
DRAWN	Dan	04/29/10			
APPROVED					
MATERIAL					
TREATMENT			TITLE Impeller Monitor		
UNLESS OTHERWISE SPECIFIED DIMENSIONS ARE IN MILLIMETERS			SIZE A4	DWG NO	REV
1 st ANGLE ANGLES ±0.1°			FILE NAME: Impeller Monitor.dft		
2 PL ±0.02 3 PL ±0.005			SCALE:	WEIGHT:	SHEET 5 OF 6

REVISION HISTORY			
REV	DESCRIPTION	DATE	APPROVED

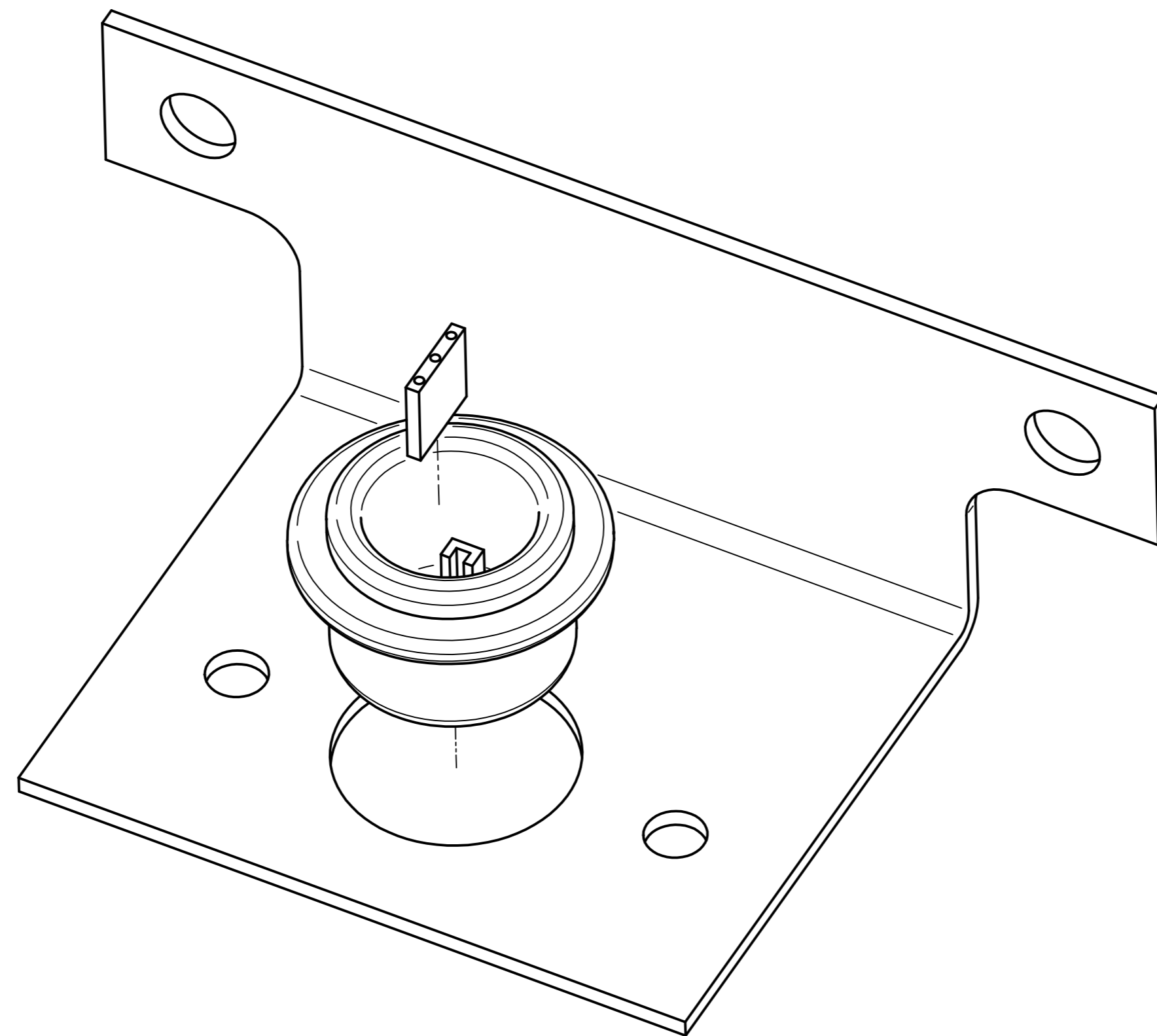

	NAME	DATE	AGRIGEL		
DRAWN	Dan	04/29/10			
APPROVED					
MATERIAL					
TREATMENT			TITLE Impeller Monitor		
UNLESS OTHERWISE SPECIFIED DIMENSIONS ARE IN MILLIMETERS			SIZE A4	DWG NO	REV
1 st ANGLE ANGLES ±0.1°			FILE NAME: Impeller Monitor.dft		
2 PL ±0.02 3 PL ±0.005			SCALE:	WEIGHT:	SHEET 6 OF 6