

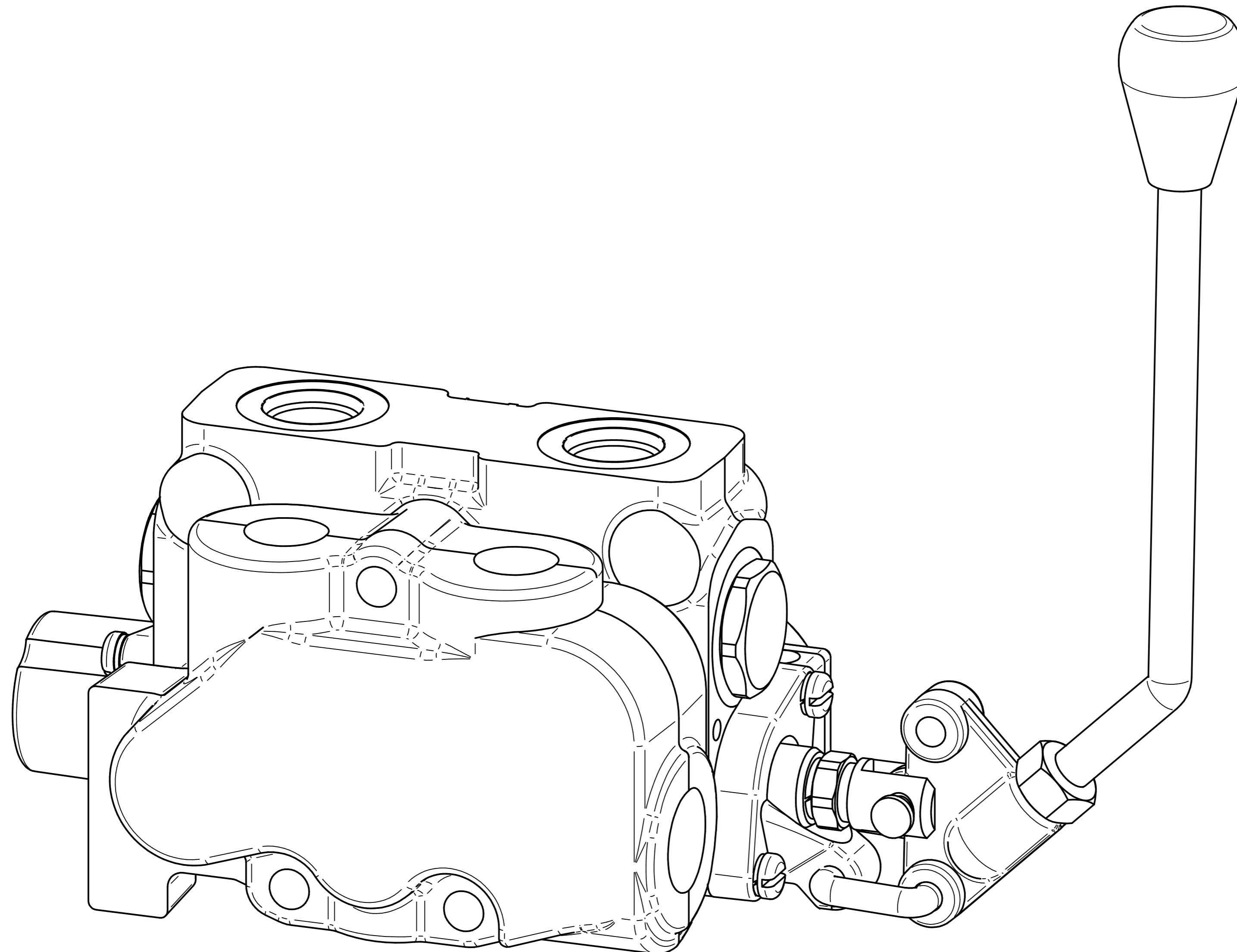



REVISION HISTORY			
REV	DESCRIPTION	DATE	APPROVED

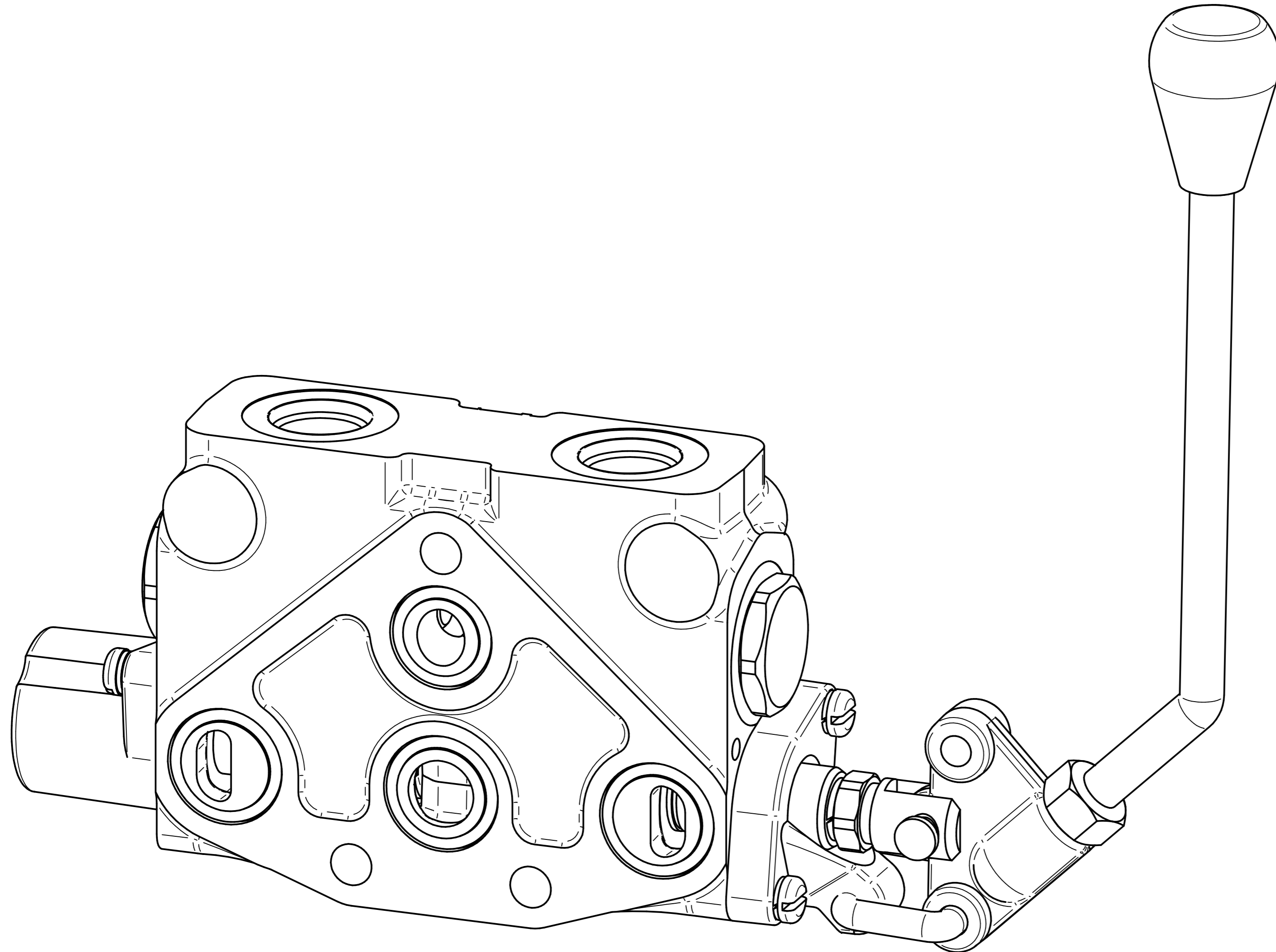

	NAME	DATE	PREMAC	
DRAWN	Dan	09/04/23	PRECISION MACHINE MANUFACTURERS (PTY)LTD.	
APPROVED			TITLE	
MATERIAL				
TREATMENT				
UNLESS OTHERWISE SPECIFIED DIMENSIONS ARE IN MILLIMETERS			SIZE A2	DWG NO
1st ANGLE 			FILE NAME: V75.dft	
2 PL ±0.02 3 PL ±0.005			SCALE:	WEIGHT: SHEET 1 OF 3

REVISION HISTORY			
REV	DESCRIPTION	DATE	APPROVED



	NAME	DATE	PREMAC	
DRAWN	Dan	09/04/23	PRECISION MACHINE MANUFACTURERS (PTY)LTD.	
APPROVED			TITLE	
MATERIAL				
TREATMENT				
UNLESS OTHERWISE SPECIFIED DIMENSIONS ARE IN MILLIMETERS ANGLES ±0.1°			SIZE A2	DWG NO
1st ANGLE 			FILE NAME: V75.dft	REV
2 PL ±0.02 3 PL ±0.005			SCALE:	WEIGHT: SHEET 2 OF 3

REVISION HISTORY			
REV	DESCRIPTION	DATE	APPROVED

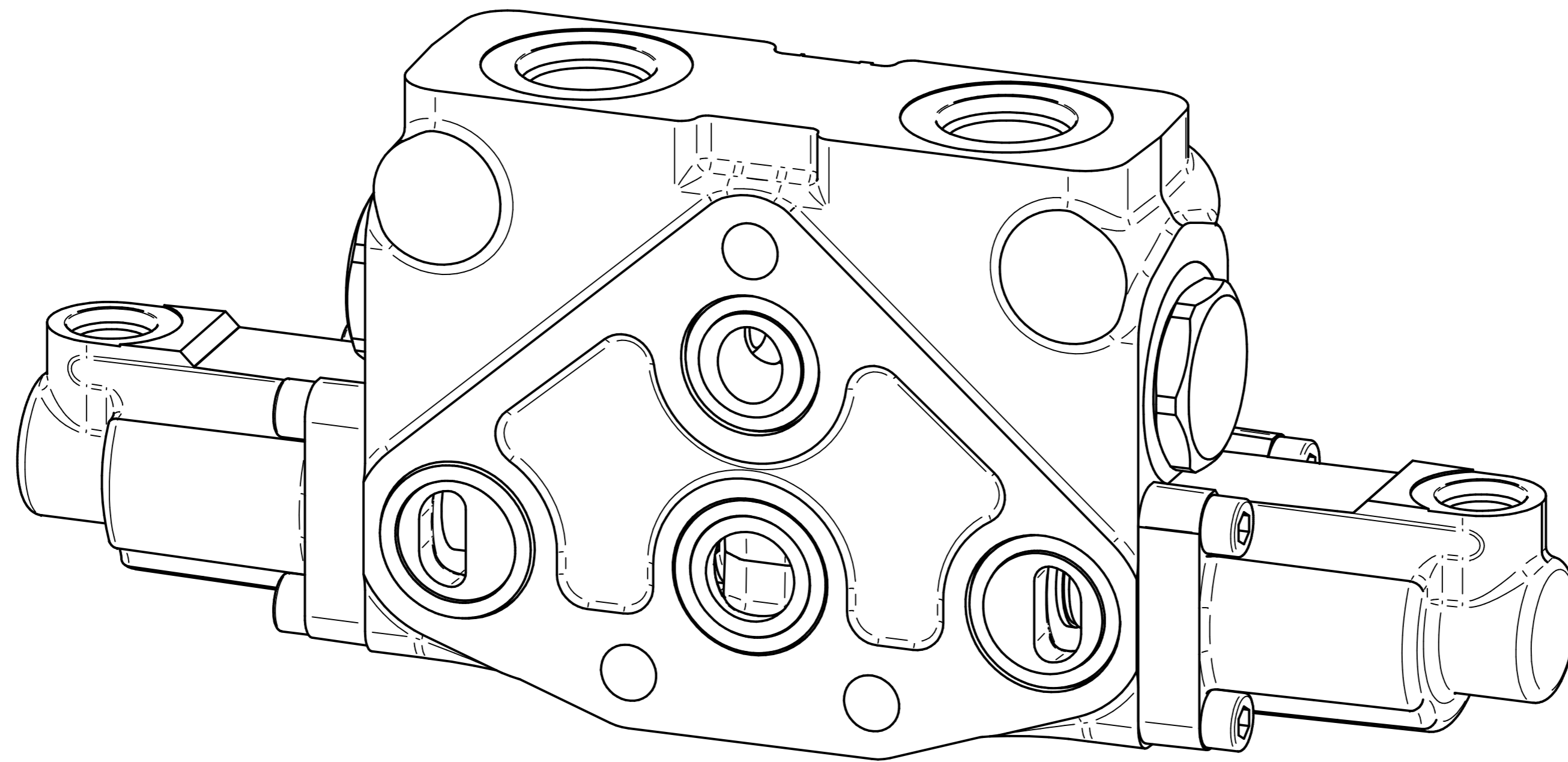

	NAME	DATE	PREMAC	
DRAWN	Dan	09/04/23	PRECISION MACHINE MANUFACTURERS (PTY)LTD.	
APPROVED			TITLE	
MATERIAL				
TREATMENT				
UNLESS OTHERWISE SPECIFIED DIMENSIONS ARE IN MILLIMETERS			SIZE A2	DWG NO
1 <sup>ST</sup> ANGLE  ANGLES ±0.1°			FILE NAME: V75.dft	
2 PL ±0.02 3 PL ±0.005			SCALE:	WEIGHT: SHEET 3 OF 3