

REVISION HISTORY

REV	DESCRIPTION	DATE	APPROVED

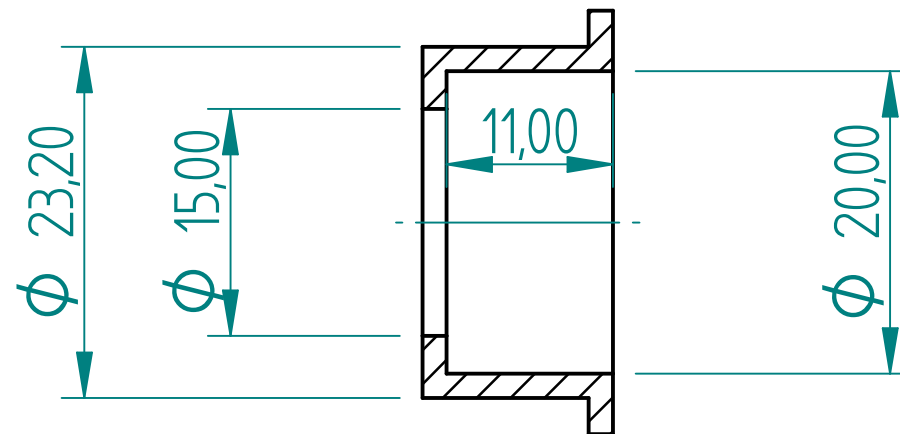
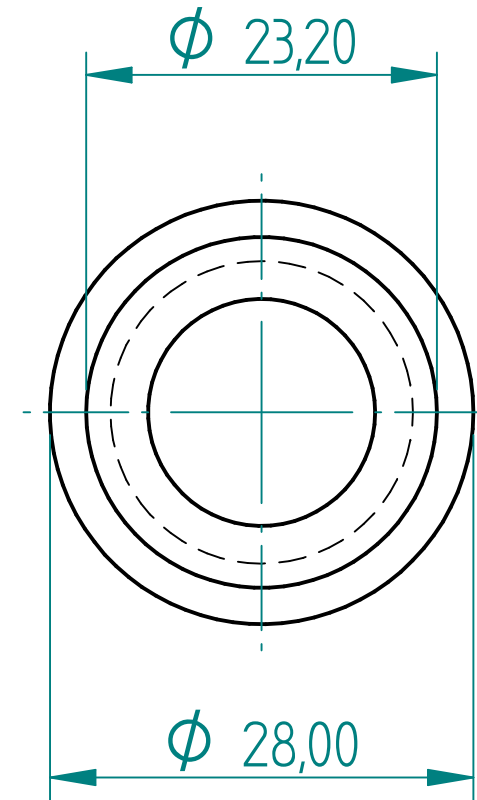
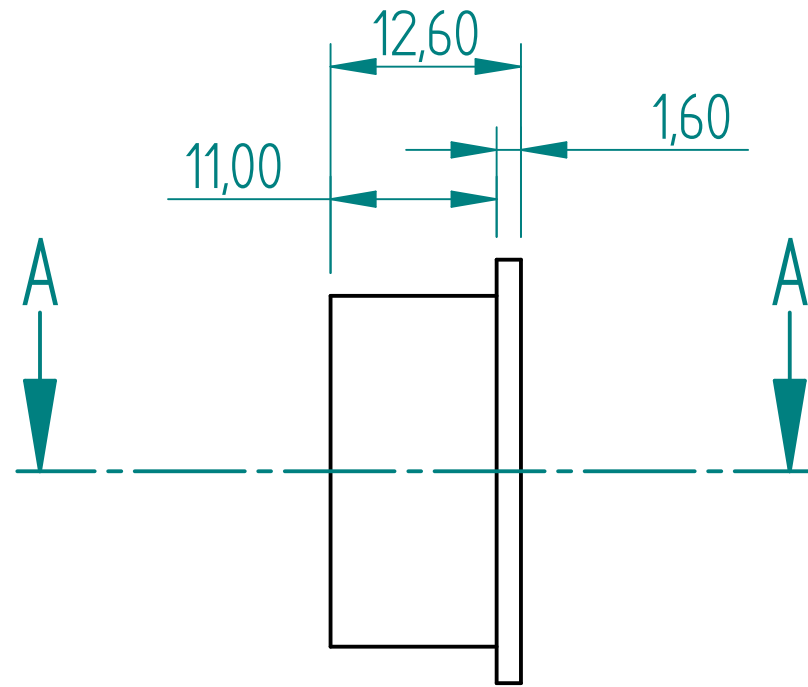

SECTION A-A

NAME	DATE	PREMAC PRECISION MACHINE MANUFACTURERS (PTY)LTD.	
DRAWN D.L.G	09/04/23		
APPROVED		TITLE V75 STD SPRING CUP	
MATERIAL		SIZE A3	DWG NO
TREATMENT		FILE NAME: Spring Cup.dft	REV
UNLESS OTHERWISE SPECIFIED DIMENSIONS ARE IN MILLIMETERS ANGLES ±0.1° 2 PL ±0.02 3 PL ±0.005		SCALE:	WEIGHT:
		SHEET 1 OF 2	

REVISION HISTORY

REV	DESCRIPTION	DATE	APPROVED

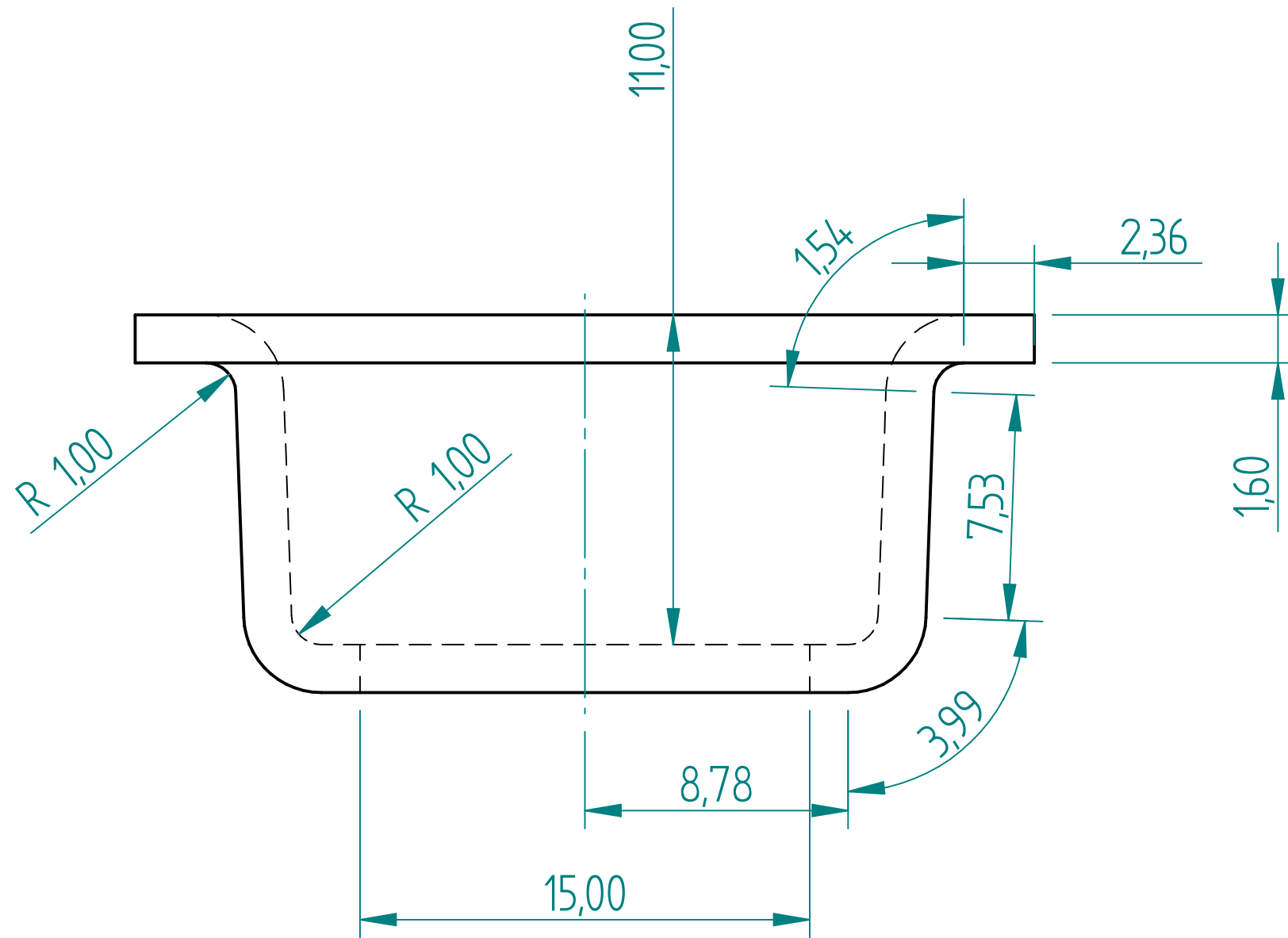

	NAME	DATE	PREMAC PRECISION MACHINE MANUFACTURERS (PTY)LTD.	
DRAWN	D.L.G	09/04/23		
APPROVED			TITLE	
MATERIAL			V75 STD SPRING CUP	
TREATMENT			SIZE	DWG NO
UNLESS OTHERWISE SPECIFIED DIMENSIONS ARE IN MILLIMETERS ANGLES ±0.1° 2 PL ±0.02 3 PL ±0.005			A3	REV
			FILE NAME: Spring Cup.dft	
1st ANGLE			SCALE:	WEIGHT:
			SHEET 2 OF 2	