

REVISION HISTORY			
REV	DESCRIPTION	DATE	APPROVED

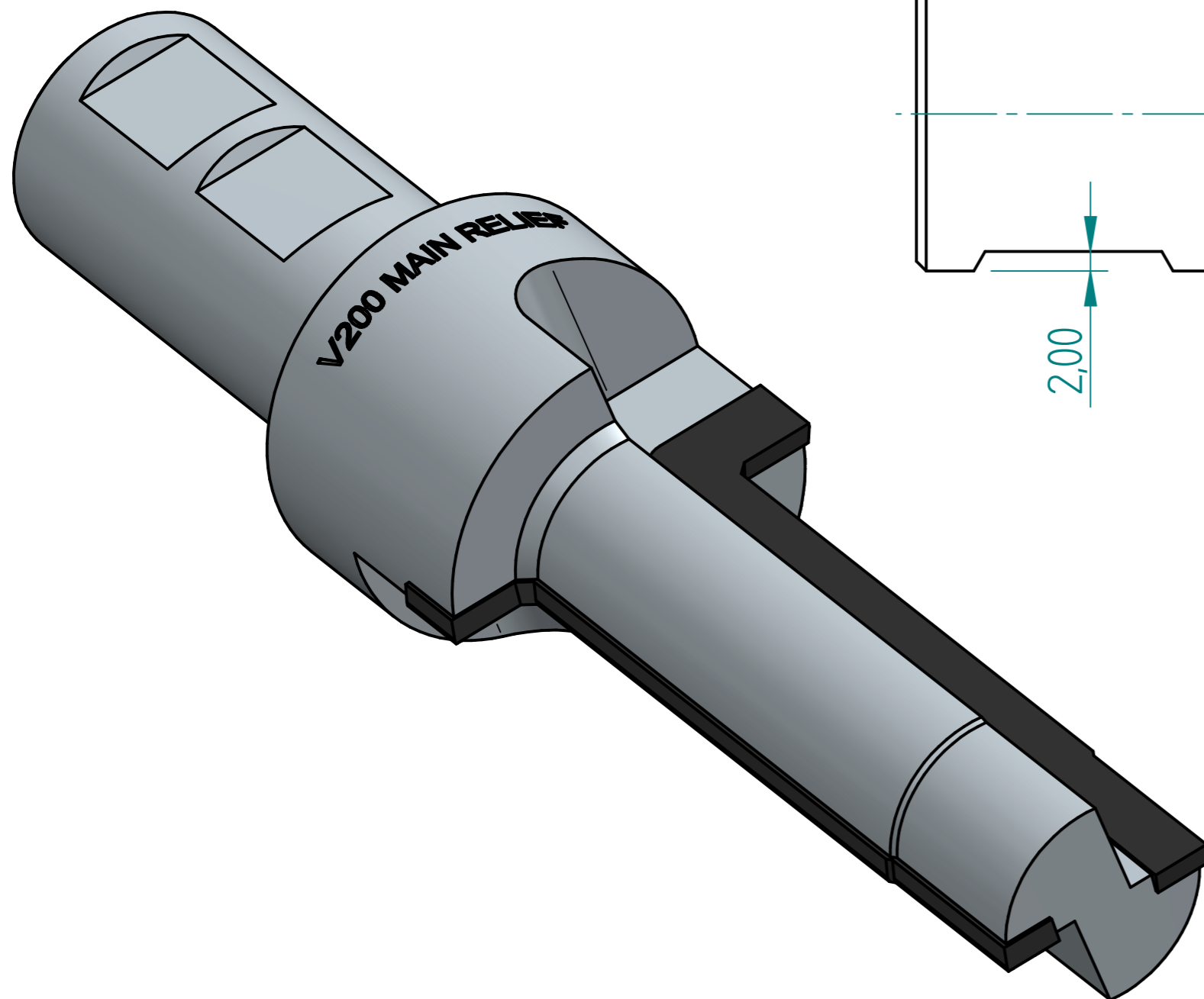
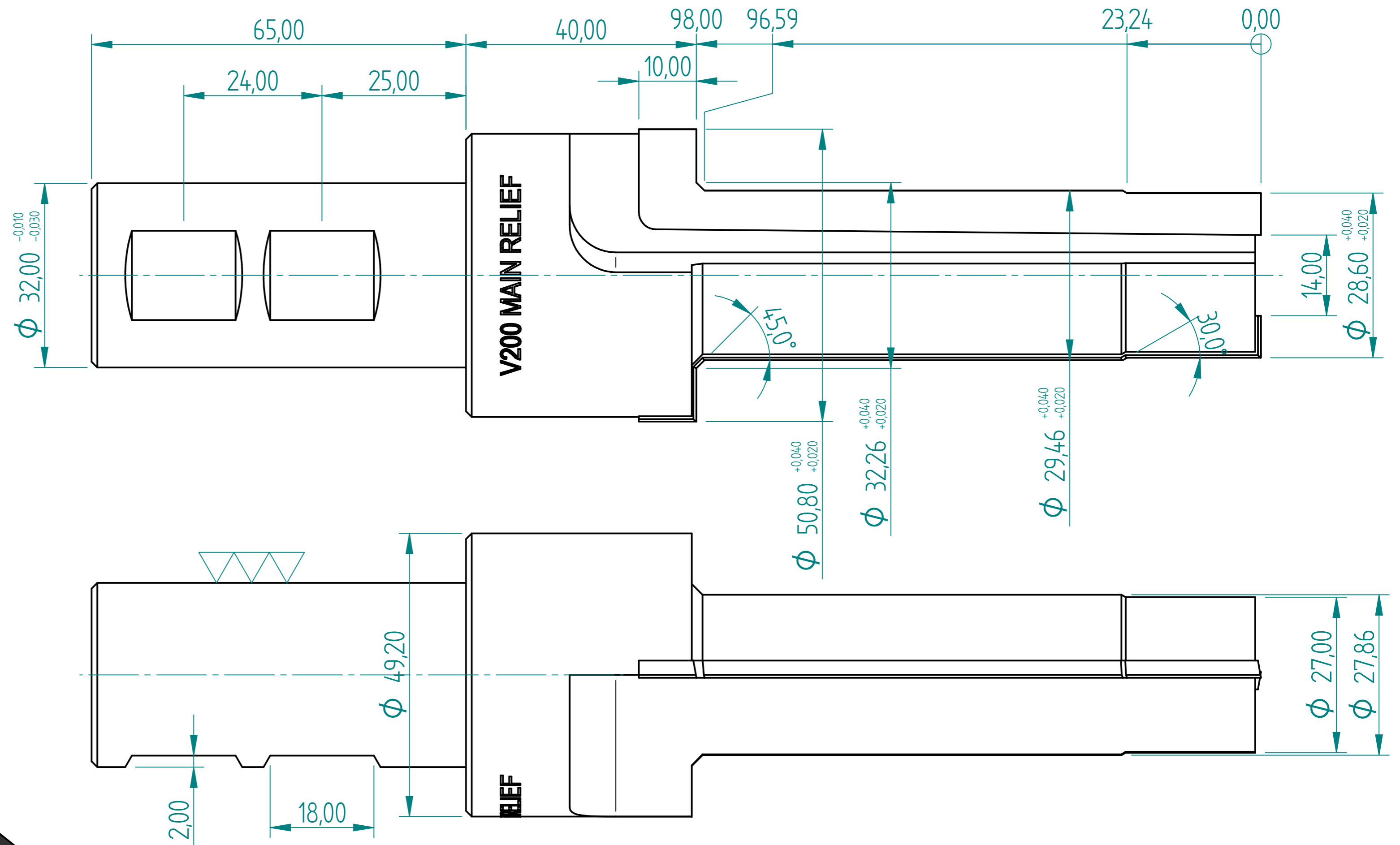
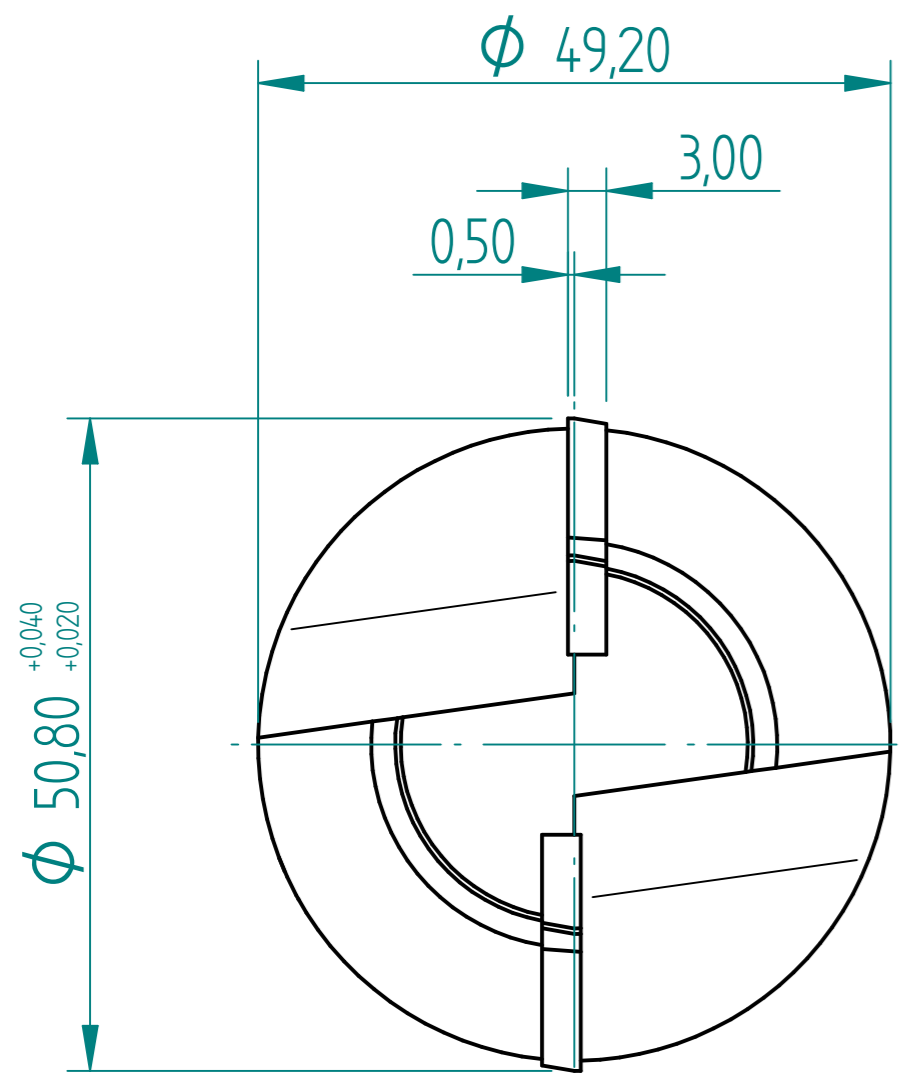

V200 Main Relief Bar
CUTTING CAST IRON

	NAME	DATE	PREMAC	
DRAWN	Dan	10/20/22		
APPROVED			TITLE	
MATERIAL			V200 Main Relief Bar	
TREATMENT			SIZE	DWG NO
UNLESS OTHERWISE SPECIFIED DIMENSIONS ARE IN MILLIMETERS			A4	
1 ST ANGLE			FILE NAME: V200 Main Relief Bar.dft	REV
2 PL $\pm 0,02$ 3 PL $\pm 0,005$			SCALE:	WEIGHT:
			SHEET 1 OF 1	