

REVISION HISTORY			
REV	DESCRIPTION	DATE	APPROVED

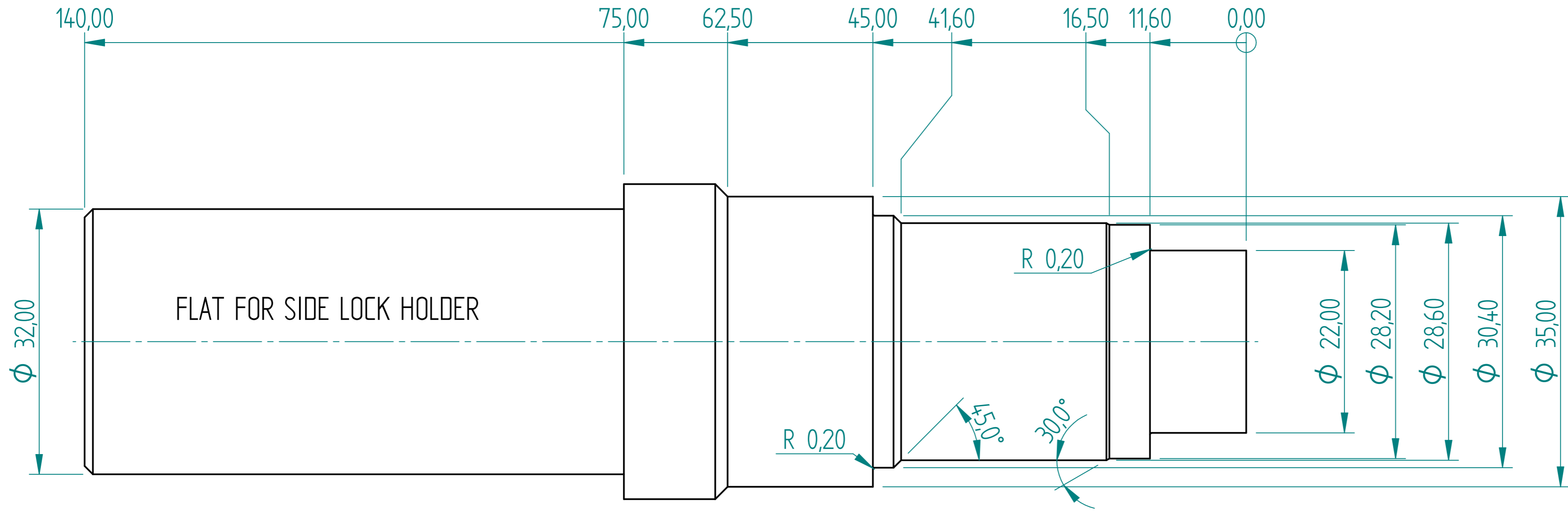

V75 MR Bar

V75 MR CAVITY SIZES  
2 CARBIDE STRIPS

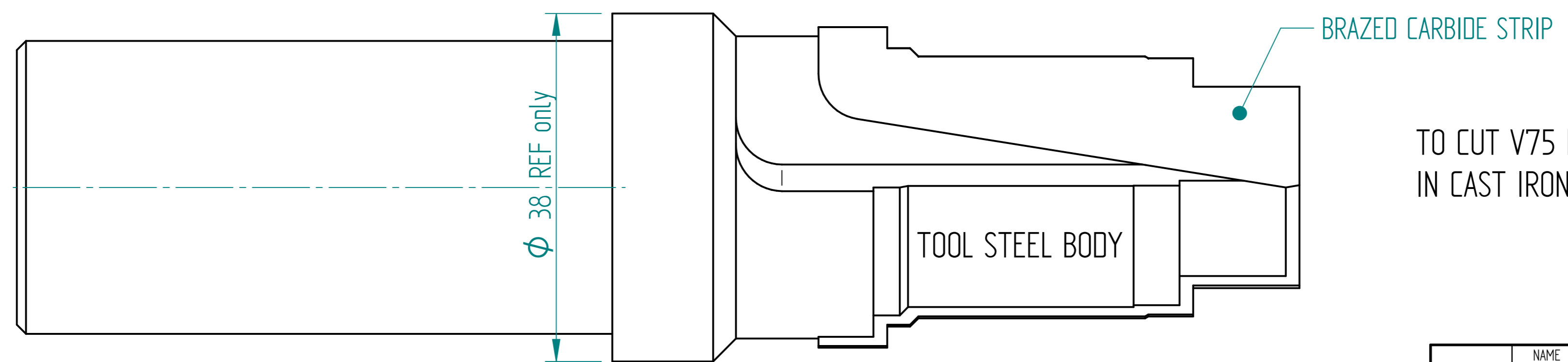

TO CUT V75 MR CAVITY  
IN CAST IRON 45mm DEEP

	NAME	DATE	<b>PREMAC</b>	
DRAWN	Dan	10/18/19		
APPROVED			TITLE	
MATERIAL				
TREATMENT				
UNLESS OTHERWISE SPECIFIED DIMENSIONS ARE IN MILLIMETERS			SIZE A4	DWG NO
1st ANGLE ANGLES ±0.1°			FILE NAME: V75 MR Bar.dft	
2 PL ±0.02 3 PL ±0.005			SCALE:	WEIGHT: SHEET 1 OF 2

REVISION HISTORY			
REV	DESCRIPTION	DATE	APPROVED

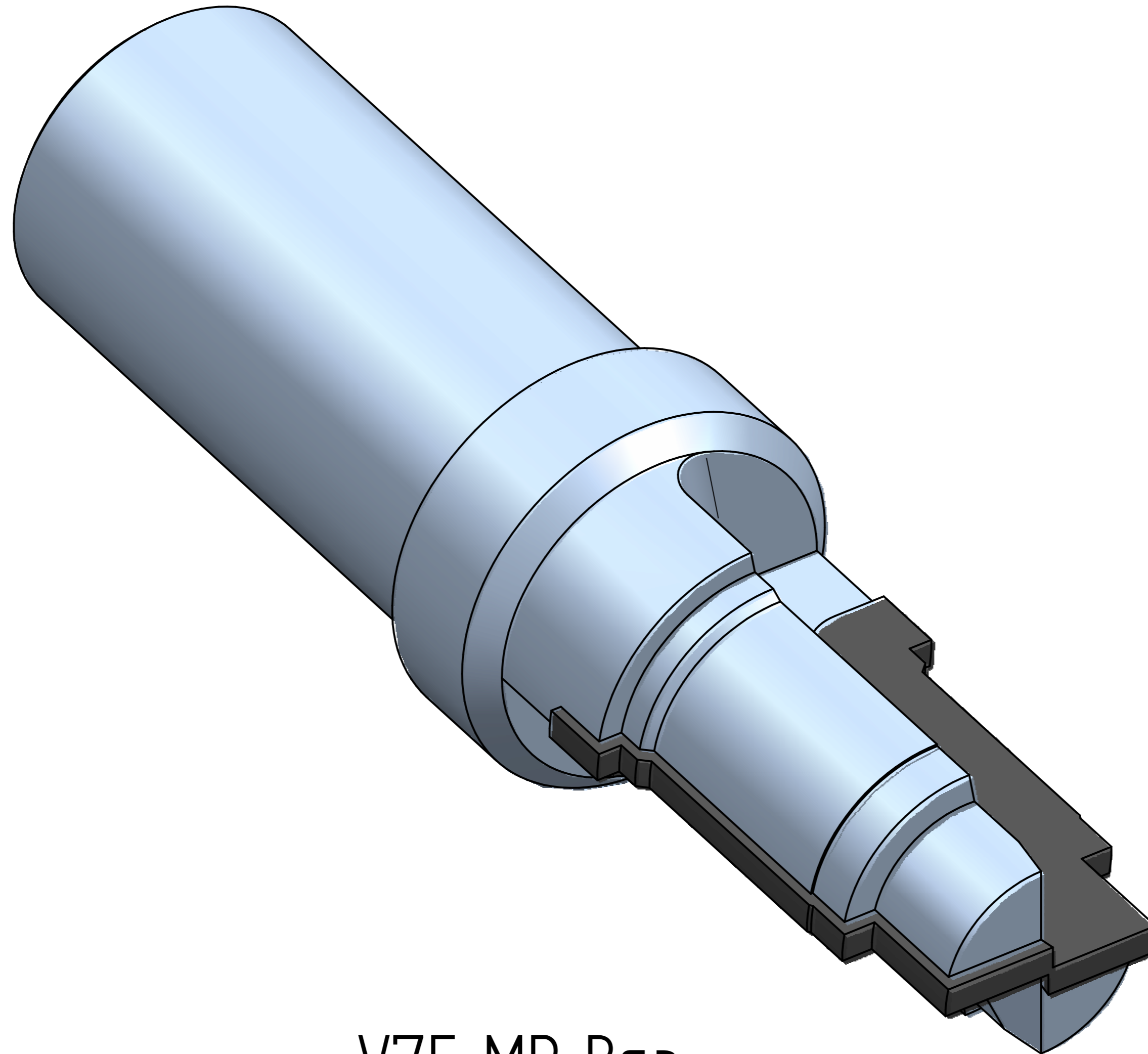

V75 MR Bar

	NAME	DATE	<b>PREMAC</b>		
DRAWN	Dan	10/18/19			
APPROVED			TITLE		
MATERIAL					
TREATMENT			SIZE	DWG NO	REV
UNLESS OTHERWISE SPECIFIED DIMENSIONS ARE IN MILLIMETERS			A4		
1st ANGLE ANGLES ±0.1°			FILE NAME: V75 MR Bar.dft		
2 PL ±0.02 3 PL ±0.005			SCALE:	WEIGHT:	SHEET 2 OF 2