

Item Number	Document Number	Title	Quantity	Item Number	Document Number	Title	Quantity
1		Lever Assembly	1	8	PV150-0023	Motor Spool	1
2		Load Holding Check Asm	1	9	PV150-0045	Clevis	1
3		Port Relief	2	10	PV150-0050	Spool Sealing Washer	2
4		Std Bonnet Asm	1	11	PV150-0056	Std Spring Cup	2
5	2-127	O-Ring	2	12	PV150-0057	Std Spool Spring	1
6	2-212	O-Ring	2	13	PV150-0058	Std Spool Positioner	1
7	PV150-0010	Std Housing V150	1	14	WS 10	Spring Washer	1

REVISION HISTORY			
REV	DESCRIPTION	DATE	APPROVED

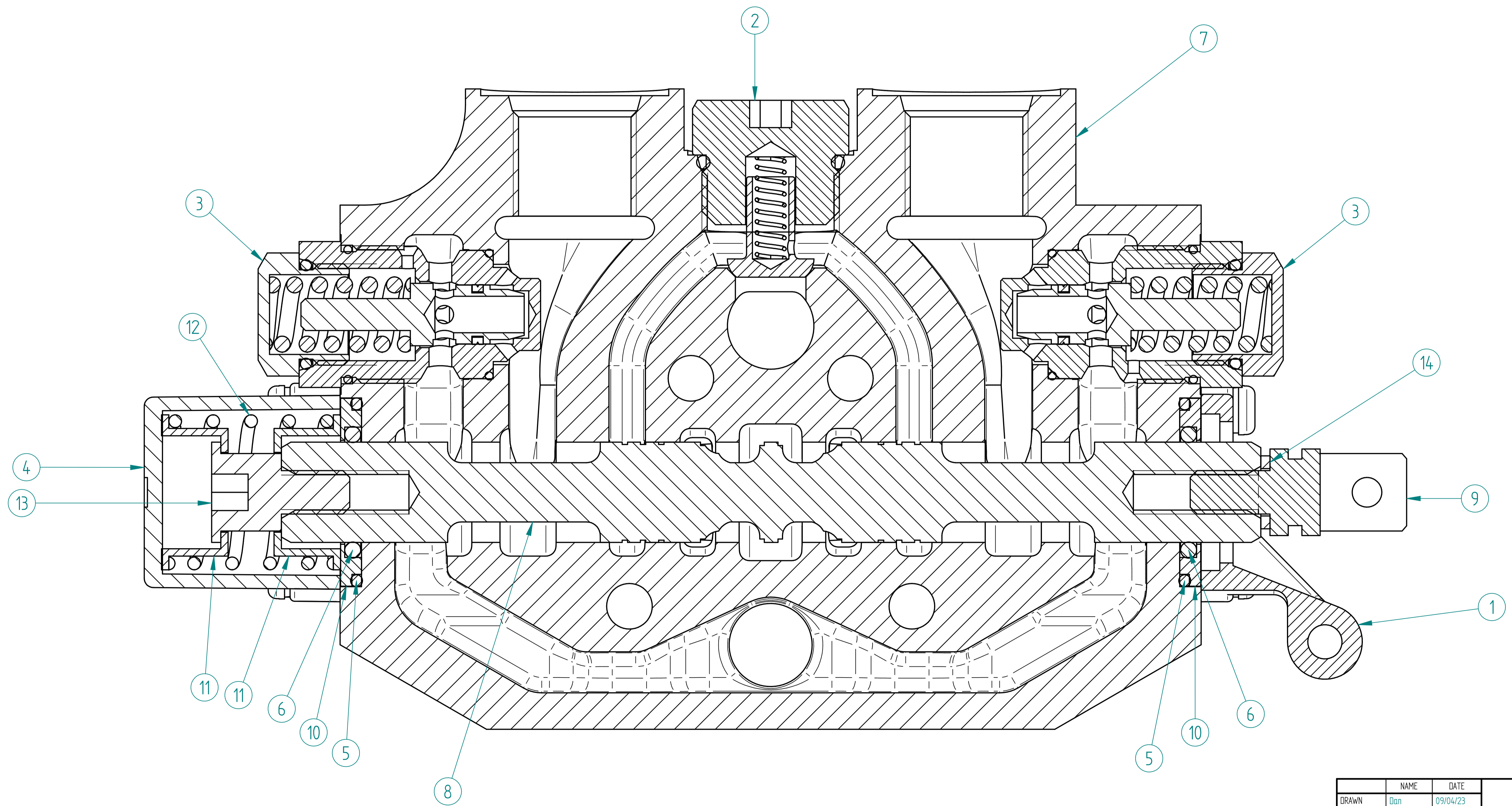

## V150 MOTOR SPOOL

NAME	DATE	PREMAC	
DRAWN Dan	09/04/23	PRECISION MACHINE MANUFACTURERS (PTY)LTD.	
APPROVED		TITLE V150 Motor Lever	
MATERIAL		SIZE A1	DWG NO
TREATMENT		FILE NAME Motor Lever.dft	REV
UNLESS OTHERWISE SPECIFIED DIMENSIONS ARE IN MILLIMETERS ANGLES *XX°		SCALE:	WEIGHT:
1:1 UNLESS SHOWN OTHERWISE	2 PL ±0.02 3 PL ±0.005		SHEET 1 OF 2

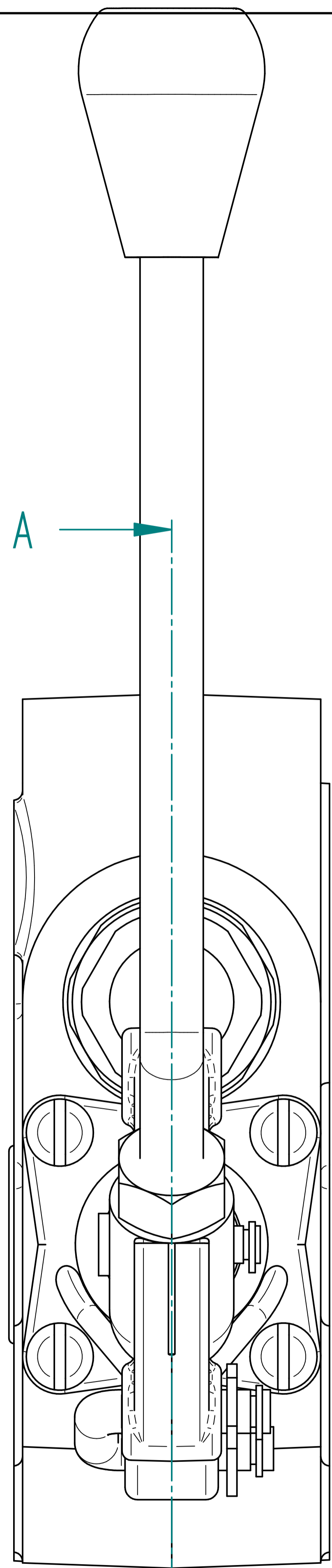

REVISION HISTORY			
REV	DESCRIPTION	DATE	APPROVED

	NAME	DATE	PREMAC	
DRAWN	Dan	09/04/23	PRECISION MACHINE MANUFACTURERS (PTY)LTD.	
APPROVED			TITLE	
MATERIAL			V150 Motor Lever	
TREATMENT			SIZE	DWG NO
UNLESS OTHERWISE SPECIFIED DIMENSIONS ARE IN MILLIMETERS ANGLES +XX°			A1	
1:1 UNLESS SHOWN OTHERWISE	2 PL ±0.02	3 PL ±0.005	FILE NAME: Motor Lever.dft	REV
	SCALE:	WEIGHT:	SHEET 2 OF 2	