

REVISION HISTORY			
REV	DESCRIPTION	DATE	APPROVED

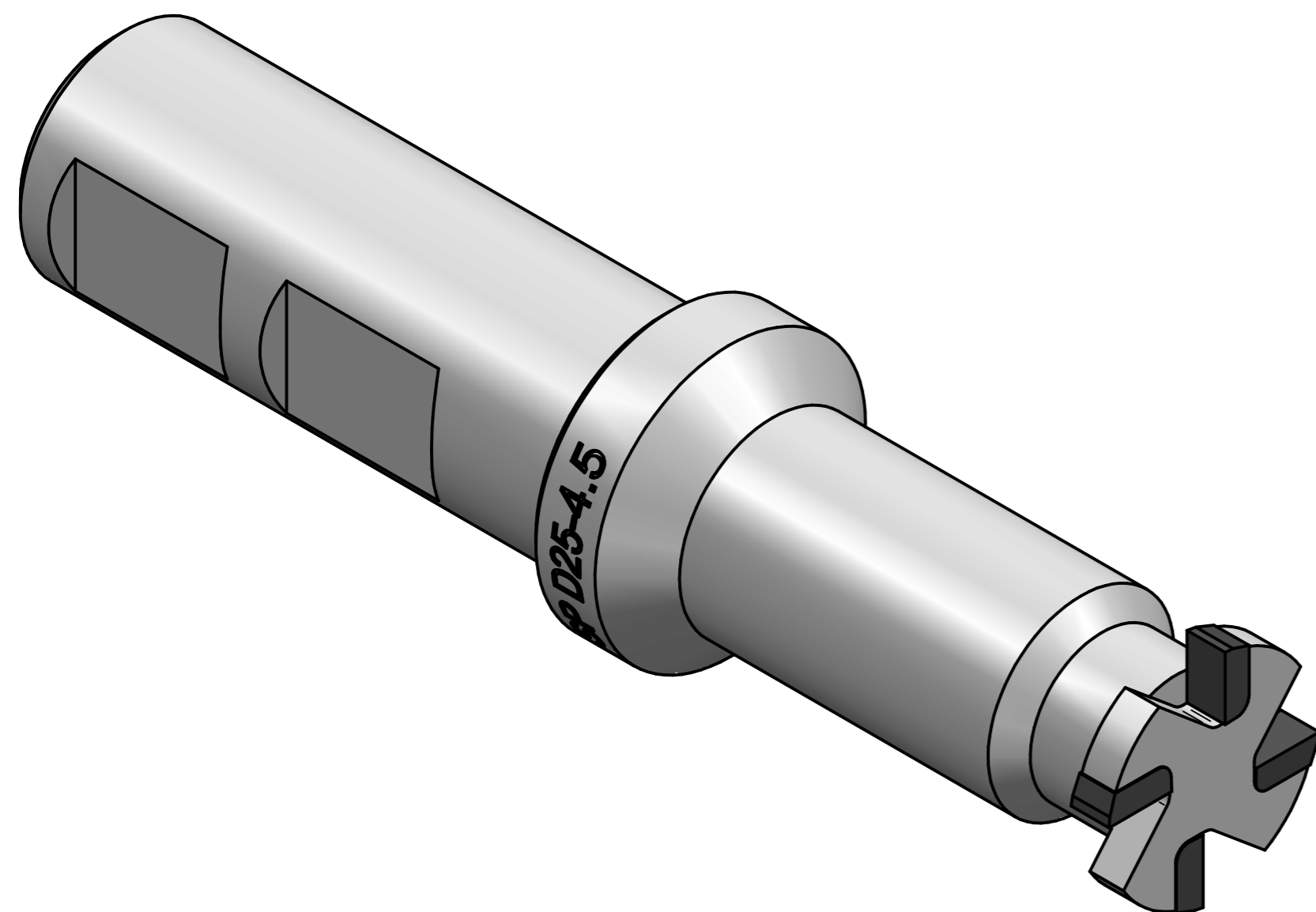
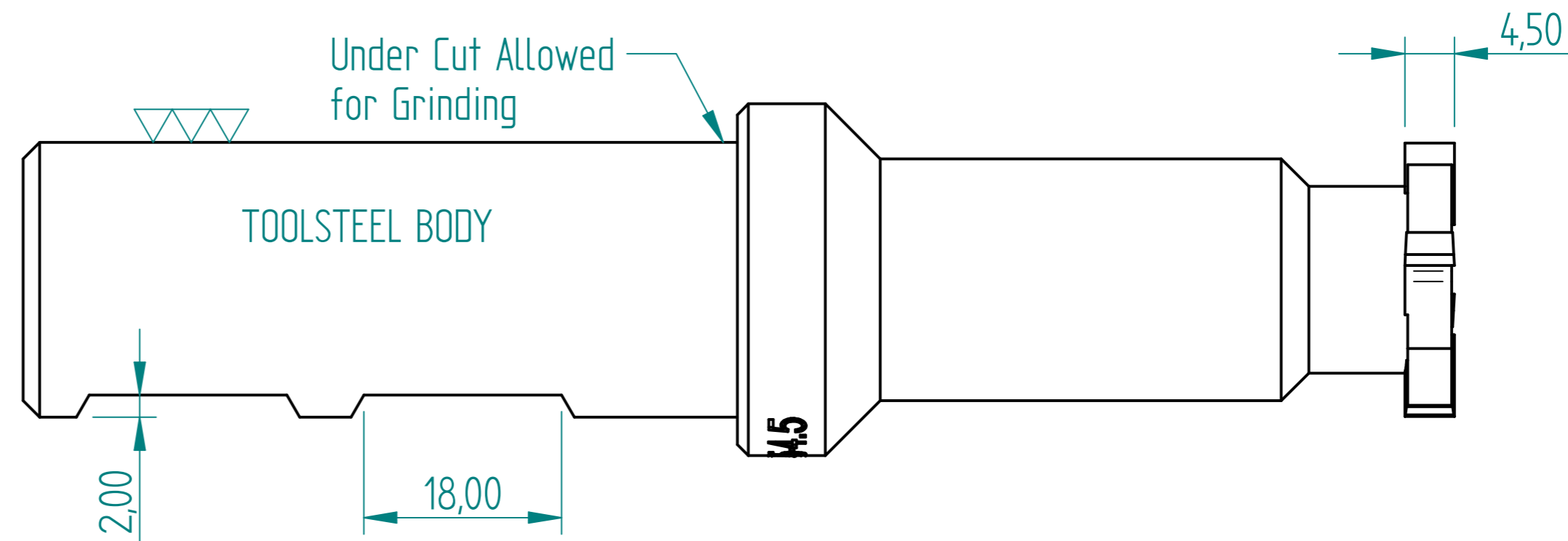
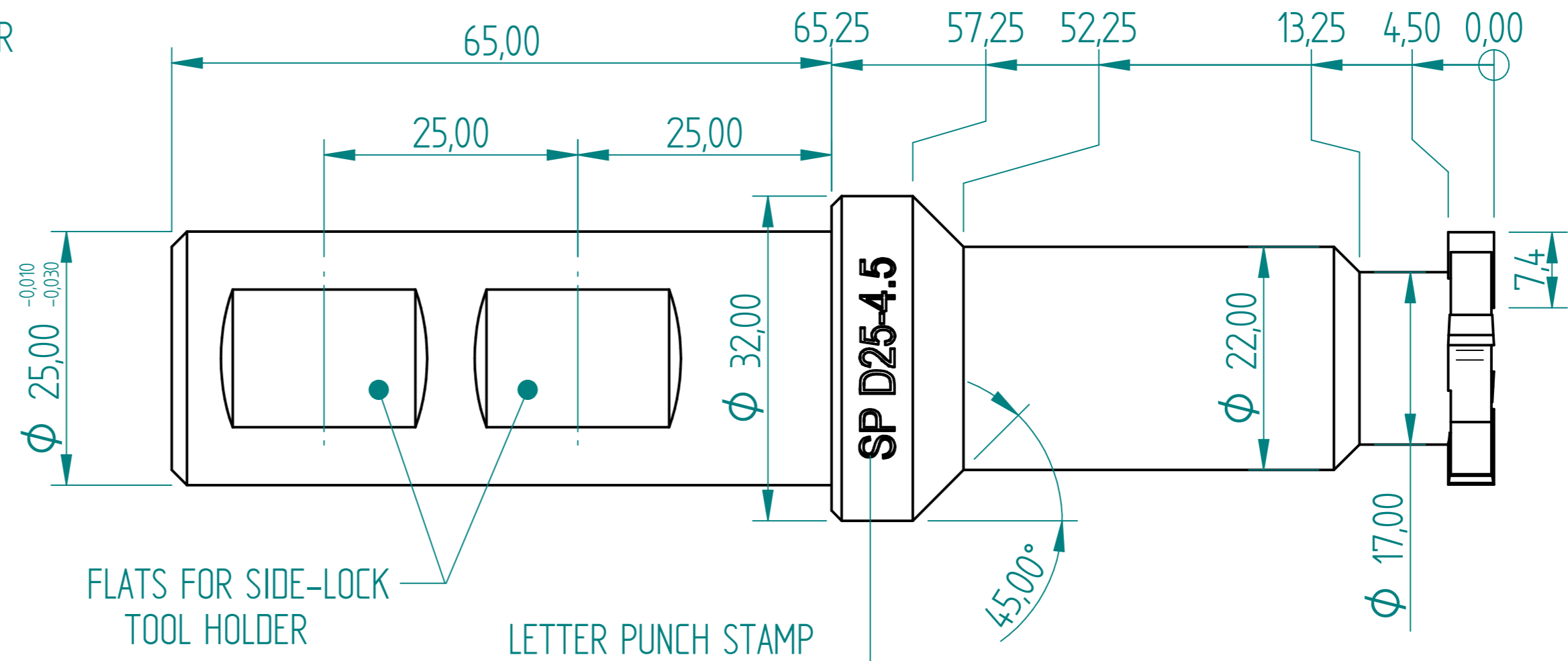
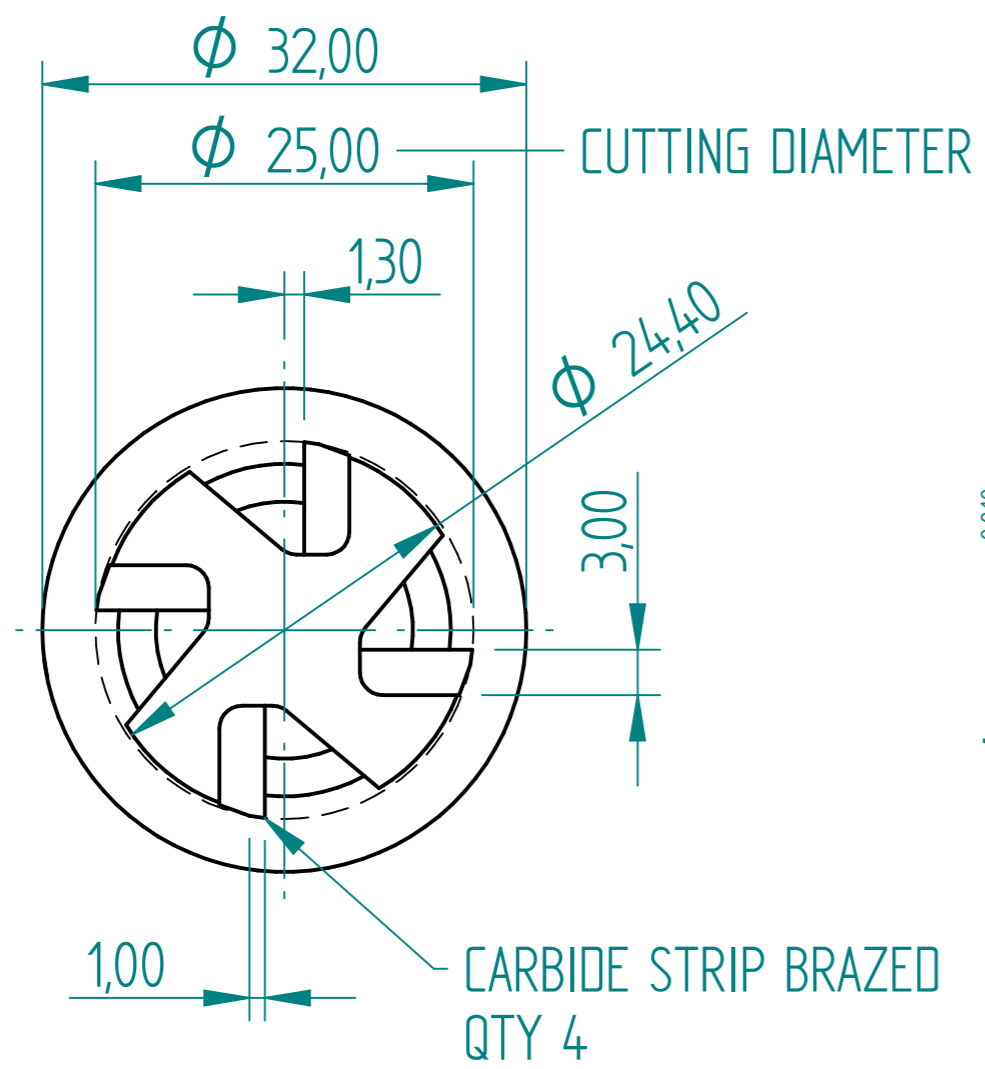

used for Machining O-Ring Groove in Cast Iron
Tool Dia 25mm - 4,5mm Wide

DRAWN	NAME	DATE	PREMAC	
APPROVED	Dan	02/22/22		
MATERIAL			TITLE	
TREATMENT			FILE NAME: O-Ring Bar.dft	
UNLESS OTHERWISE SPECIFIED DIMENSIONS ARE IN MILLIMETERS			SIZE A4	DWG NO
ANGLES $\pm 0.1^\circ$			SCALE:	WEIGHT:
2 PL ± 0.02 3 PL ± 0.005			SHEET 1 OF 1	