

| REVISION HISTORY | | | |
|------------------|-------------|------|----------|
| REV | DESCRIPTION | DATE | APPROVED |
| | | | |

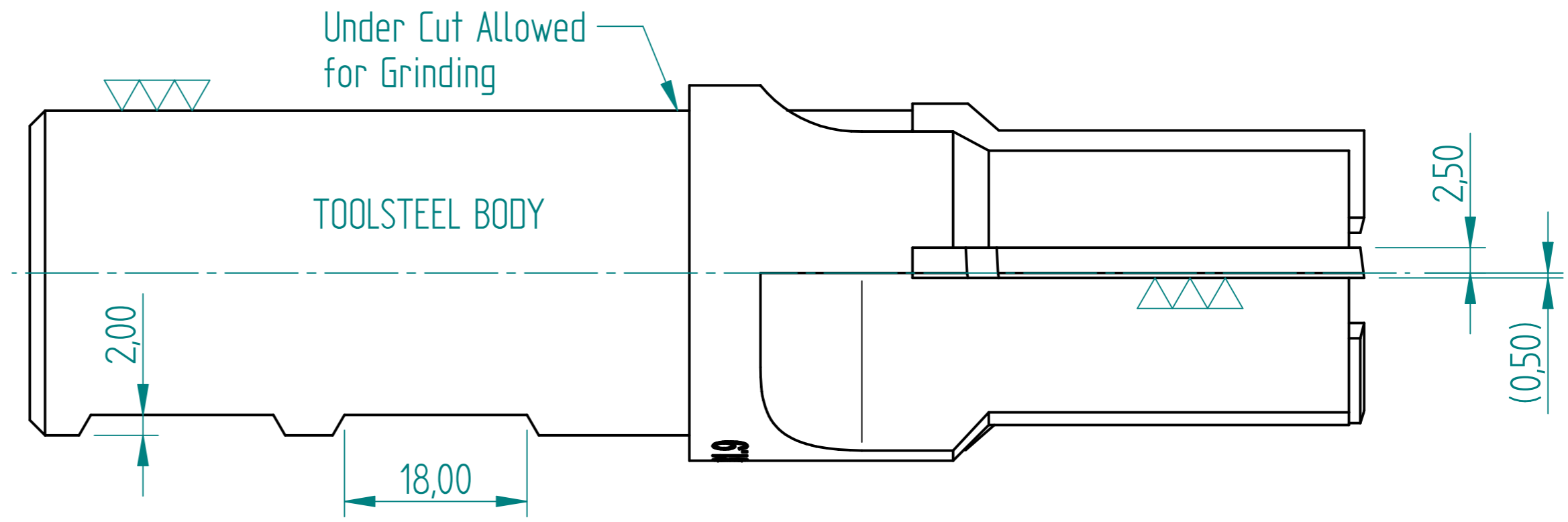
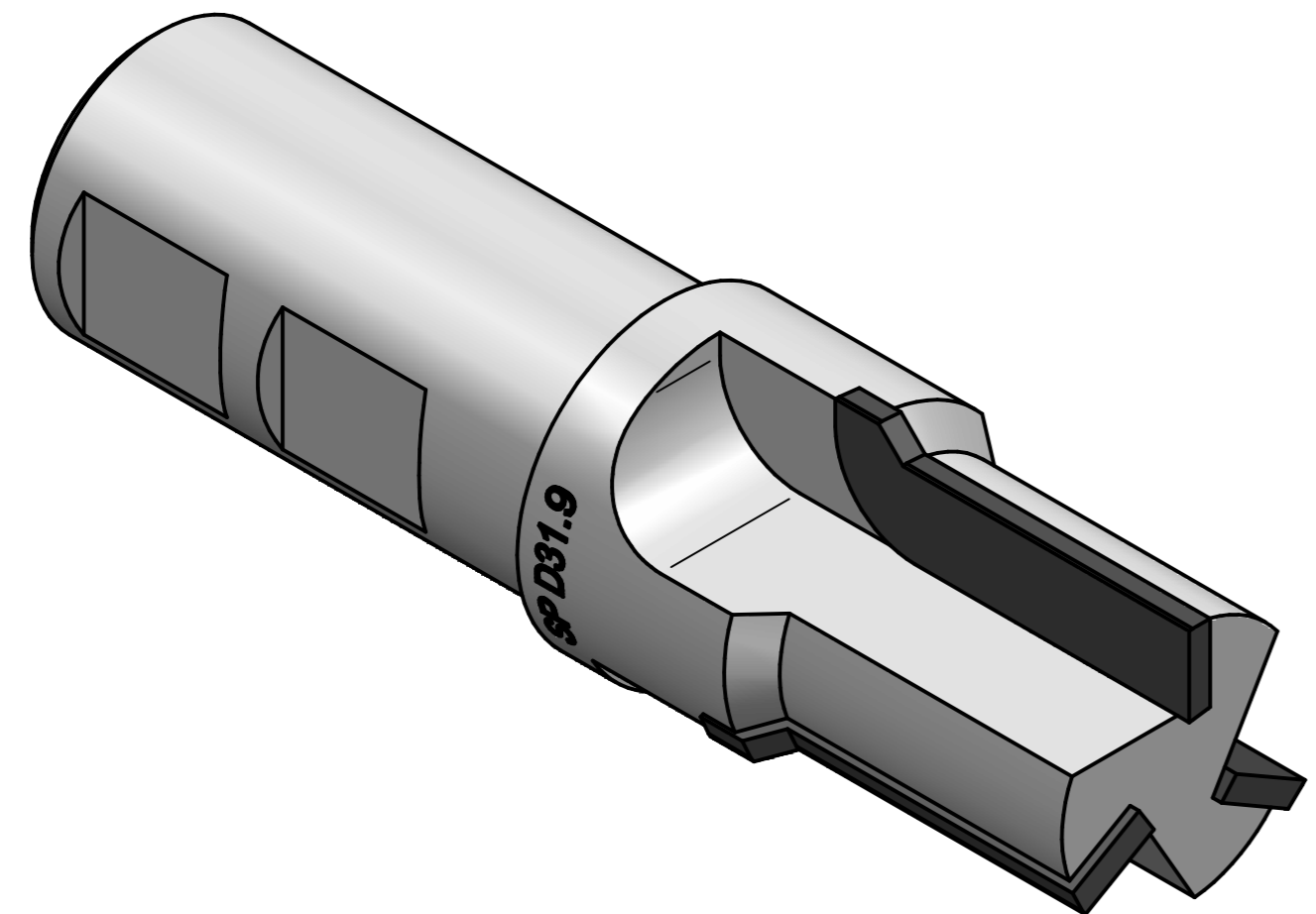
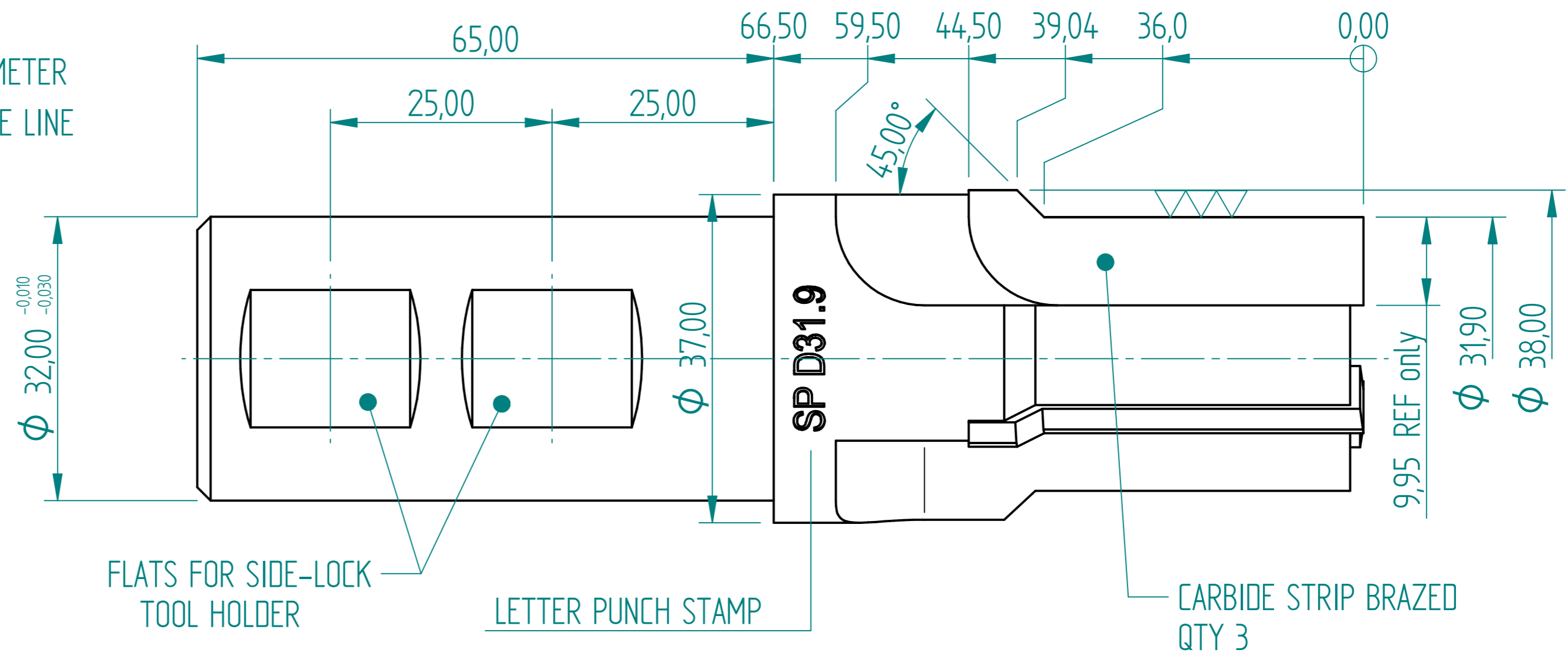
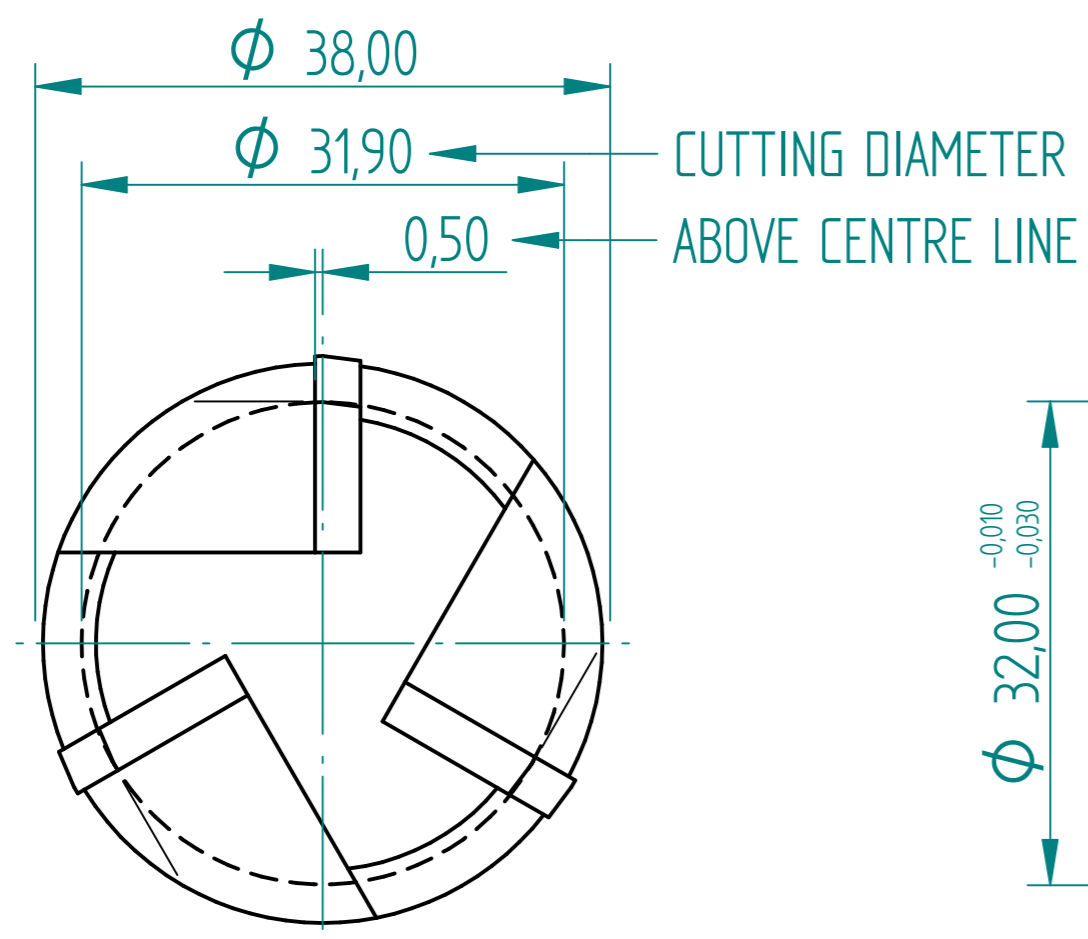

Dia 31.9 Bar
 used for Machining Dia 31.9mm
 with Chamfer in Cast Iron

| | | | | |
|--|------|----------|-----------------------------|----------------------|
| DRAWN | NAME | DATE | PREMAC | |
| APPROVED | Dan | 02/22/22 | TITLE | |
| MATERIAL | | | Dia 31.9 Bar | |
| TREATMENT | | | SIZE | DWG NO |
| UNLESS OTHERWISE SPECIFIED DIMENSIONS ARE IN MILLIMETERS | | | A4 | REV |
| 1 ST ANGLE | | | FILE NAME: Dia 31.9 Bar.dft | |
| 2 PL ±0.02 3 PL ±0.005 | | | SCALE: | WEIGHT: SHEET 1 OF 1 |