

REVISION HISTORY			
REV	DESCRIPTION	DATE	APPROVED

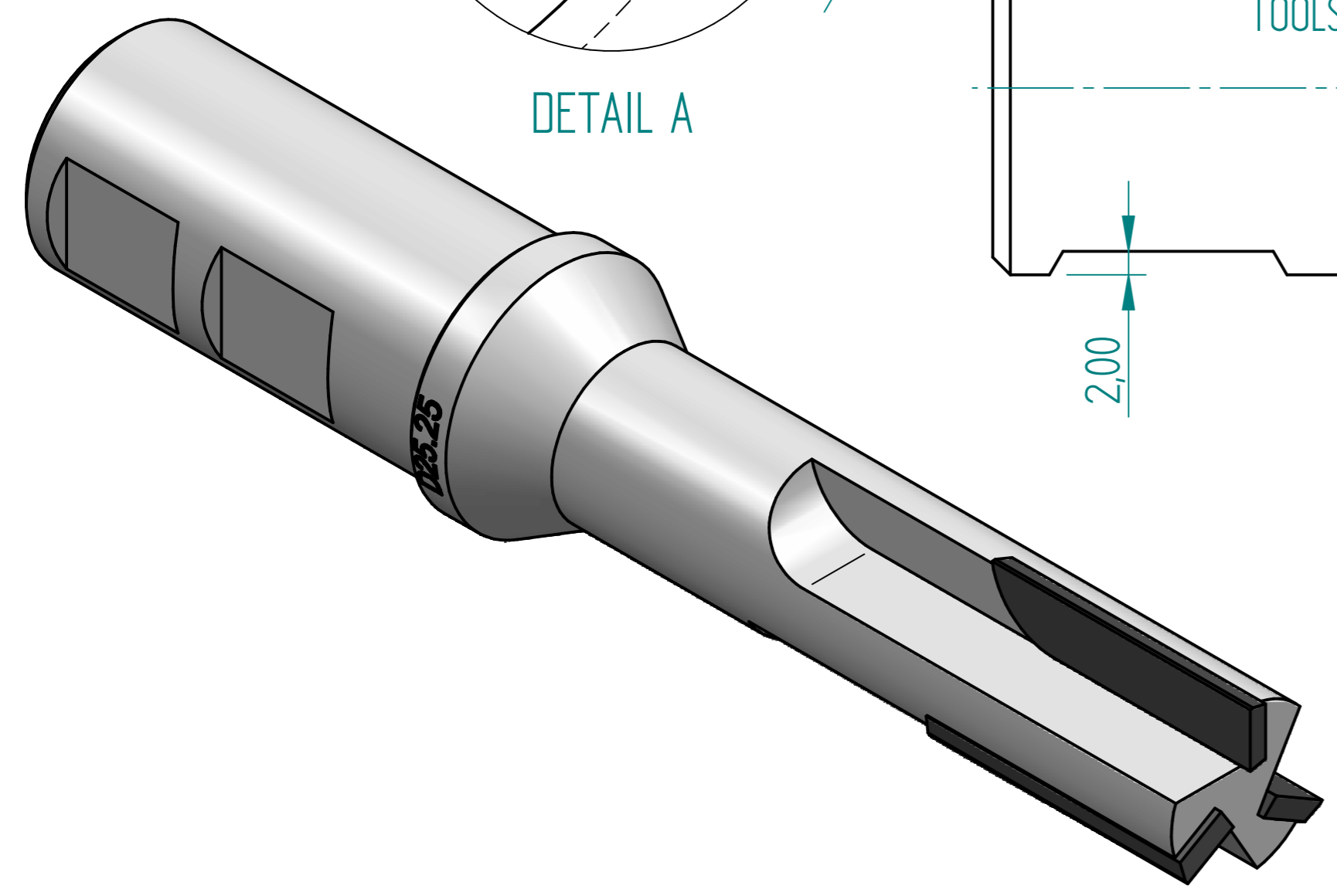
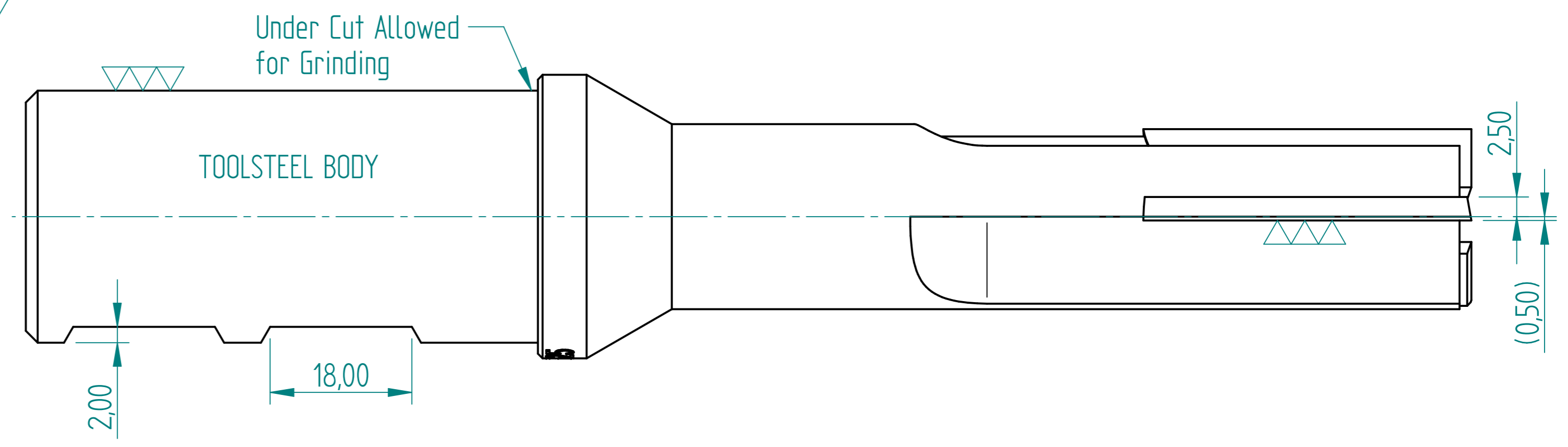
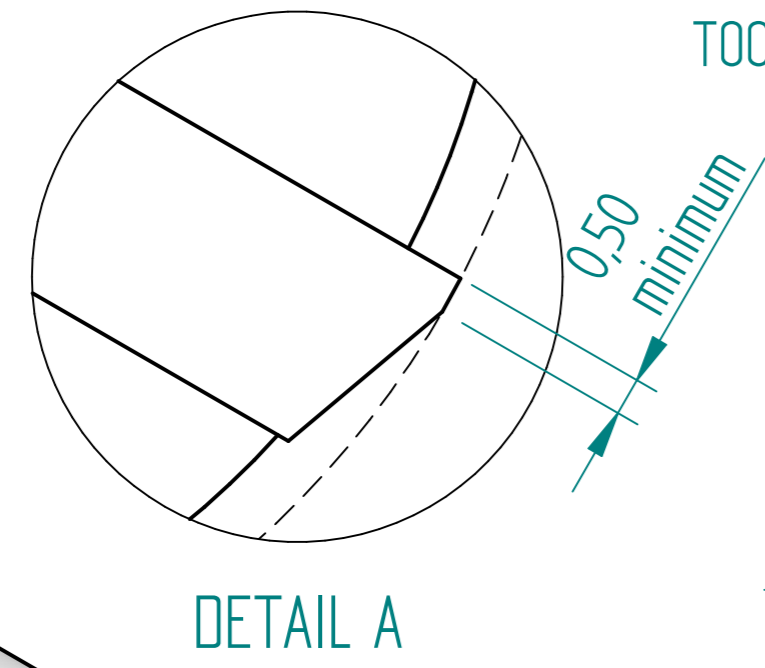
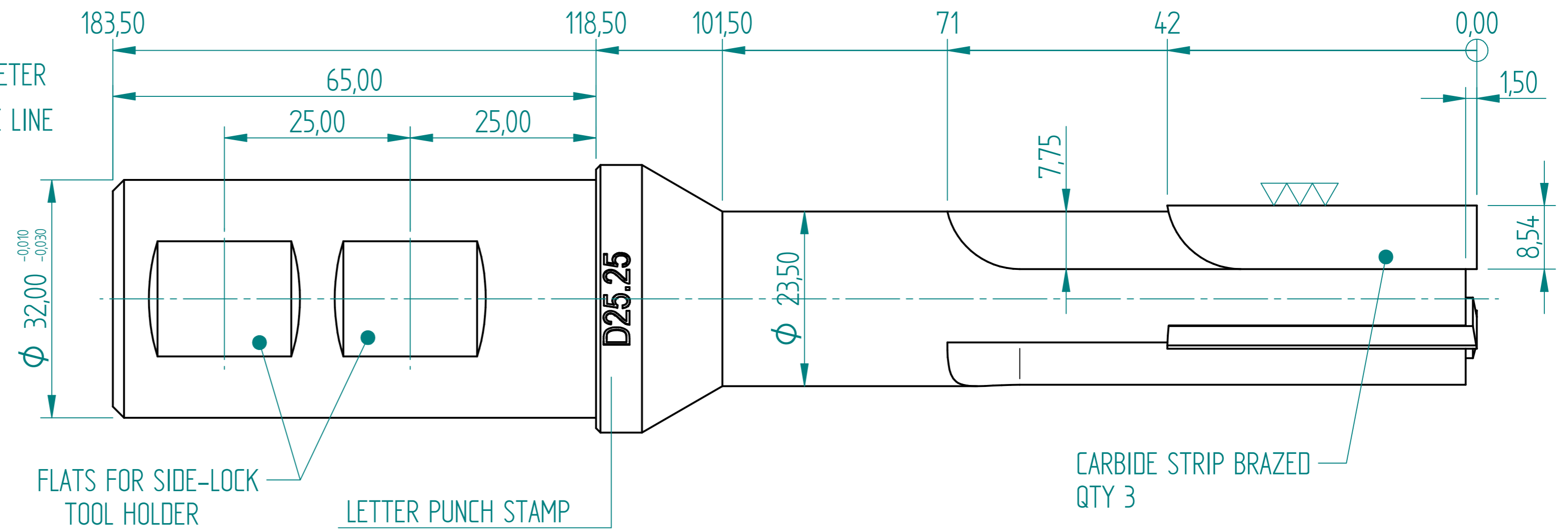
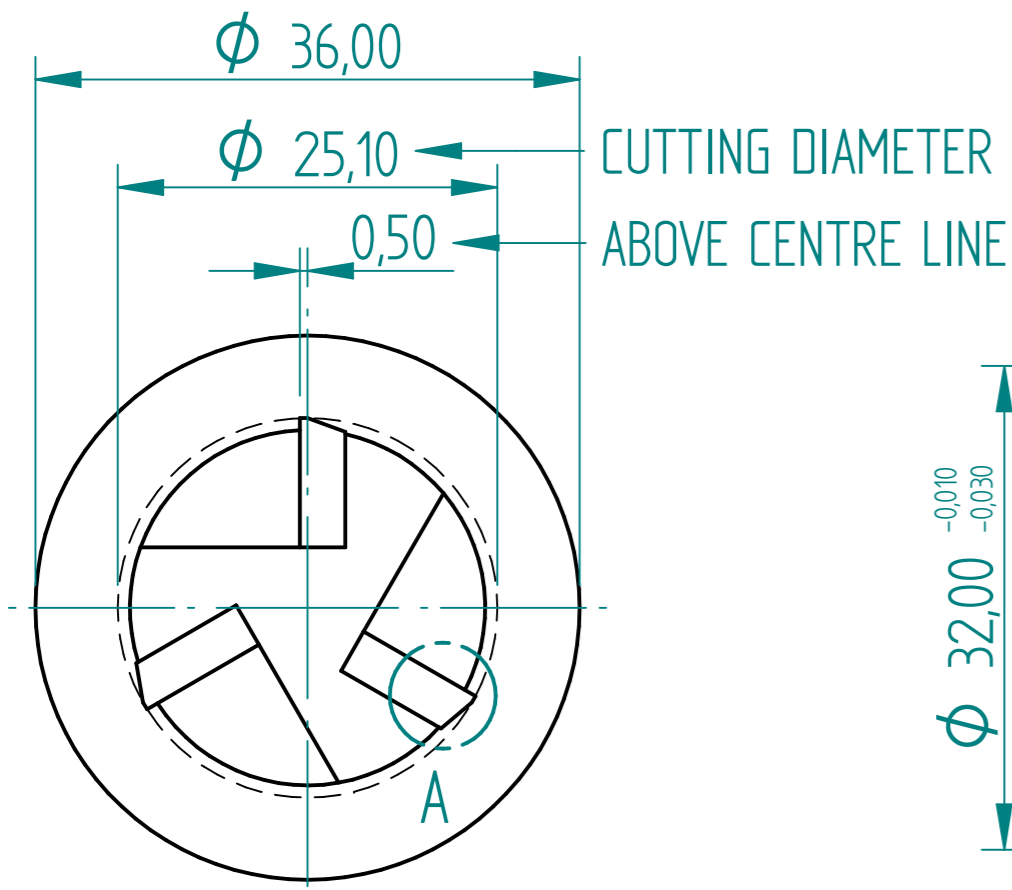

Dia 25.1 Bar
 used for Machining Dia 25.25mm
 in Cast Iron

DRAWN	NAME	DATE	PREMAC	
APPROVED	Dan	06/30/22	TITLE	
MATERIAL			Dia 25.25 Bar	
TREATMENT			SIZE A4	DWG NO
UNLESS OTHERWISE SPECIFIED DIMENSIONS ARE IN MILLIMETERS			FILE NAME: Dia_25.1 Bar.dft	REV
1 ST ANGLE			SCALE:	WEIGHT:
2 PL ±0.02 3 PL ±0.005			SHEET 1 OF 1	