

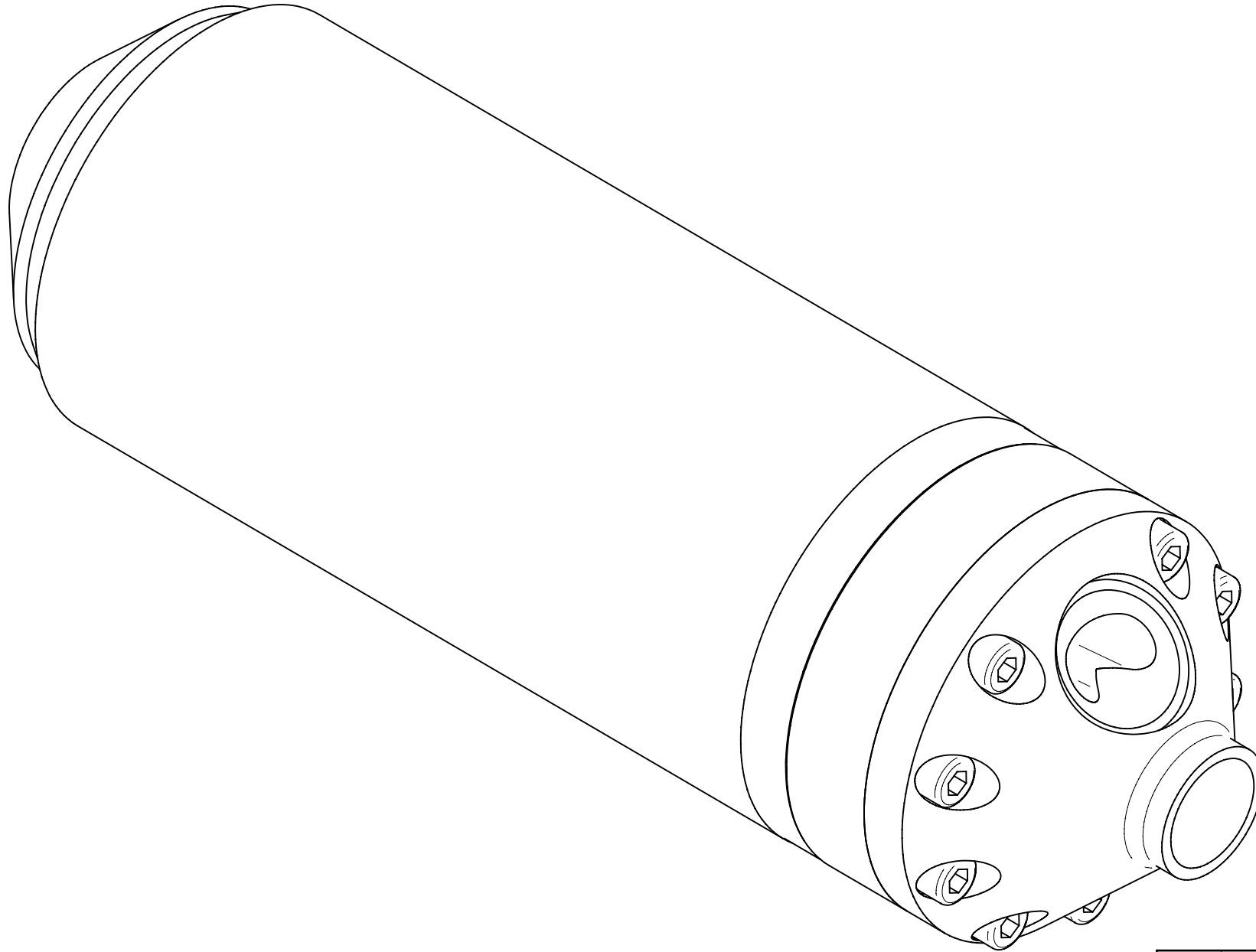

REVISION HISTORY			
REV	DESCRIPTION	DATE	APPROVED



10.82Kg

HYDROFLOOR FILTER

	NAME	DATE	PREMAC	
DRAWN	Dan	12/24/07	PRECISION MACHINE MANUFACTURERS (PTY)LTD.	
APPROVED			TITLE	
MATERIAL			Filter	
TREATMENT				
UNLESS OTHERWISE SPECIFIED DIMENSIONS ARE IN MILLIMETERS ANGLES ±0.1°			SIZE A2	DWG NO
			FILE NAME: Filter.dft	REV
2 PL ±0.02 3 PL ±0.005			SCALE:	WEIGHT:
			SHEET 1 OF 8	

REVISION HISTORY			
REV	DESCRIPTION	DATE	APPROVED

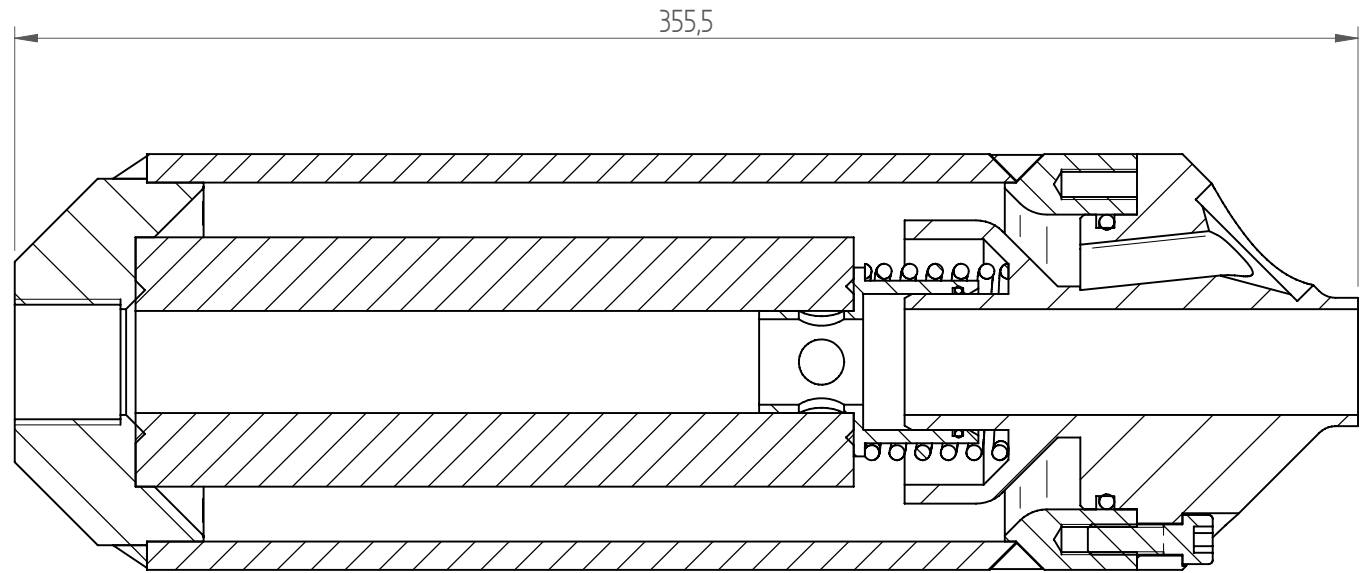
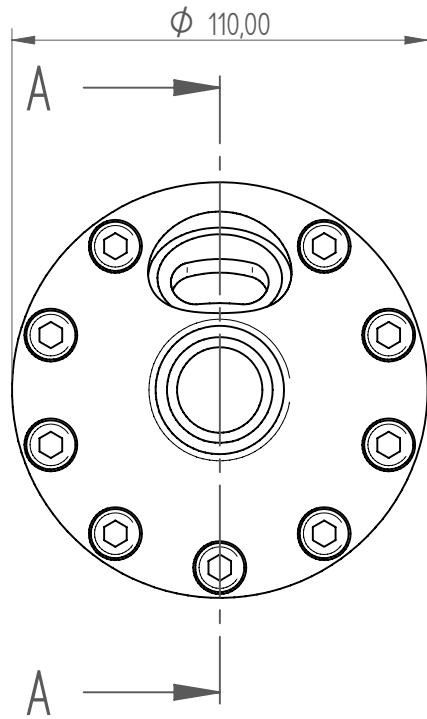

SECTION A-A

DRAWN	NAME	DATE	PREMAC	
APPROVED	Dan	12/24/07	PRECISION MACHINE MANUFACTURERS (PTY)LTD.	
MATERIAL			TITLE	
TREATMENT			Filter	
UNLESS OTHERWISE SPECIFIED DIMENSIONS ARE IN MILLIMETERS ANGLES $\pm 0,1^\circ$			SIZE A2	DWG NO
2 PL $\pm 0,02$ 3 PL $\pm 0,005$			FILE NAME: Filter.dff	REV
			SCALE:	WEIGHT:
			SHEET 2 OF 8	

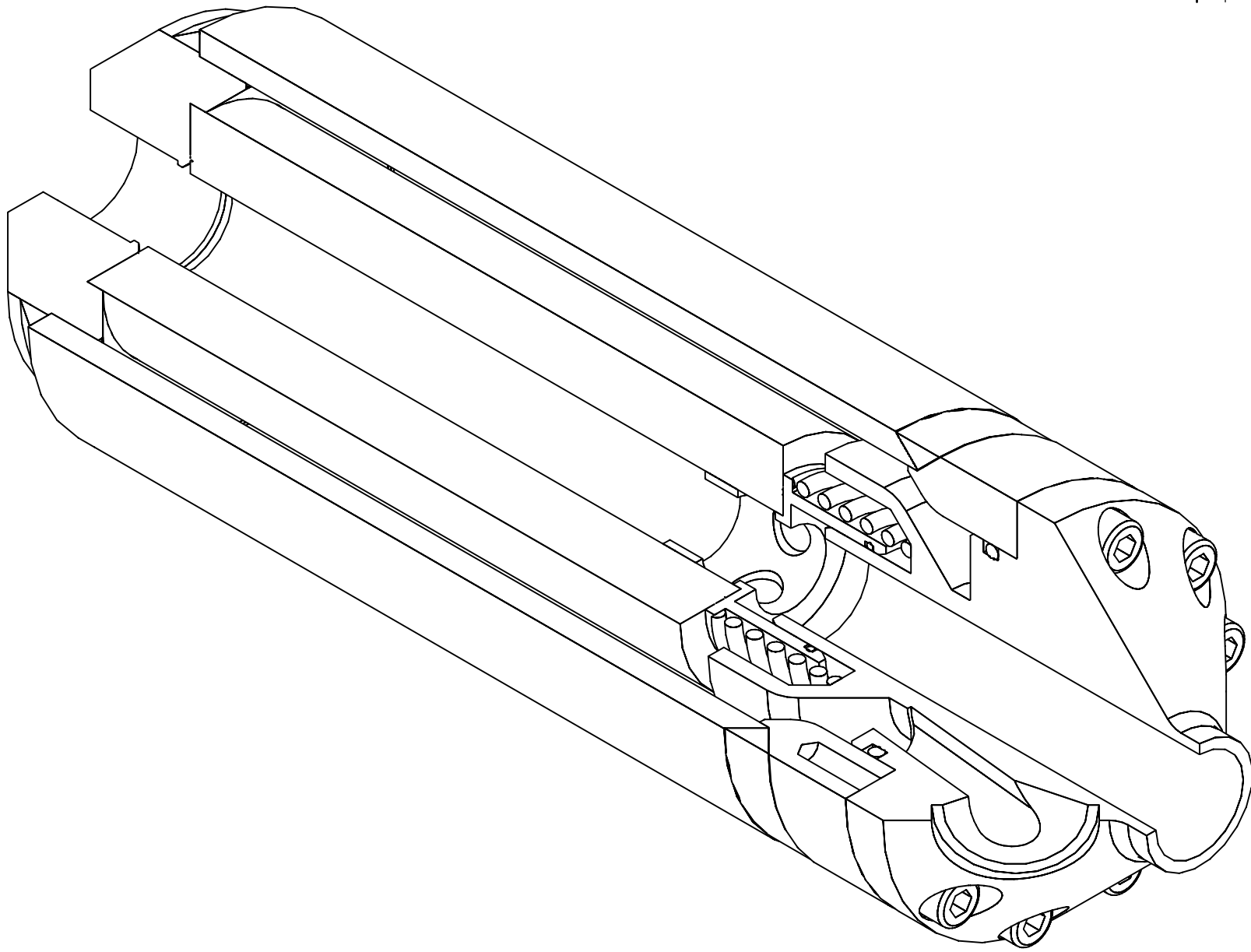

REVISION HISTORY			
REV	DESCRIPTION	DATE	APPROVED

	NAME	DATE	PREMAC	
DRAWN	Dan	12/24/07	PRECISION MACHINE MANUFACTURERS (PTY)LTD.	
APPROVED			TITLE	
MATERIAL			Filter	
TREATMENT				
UNLESS OTHERWISE SPECIFIED DIMENSIONS ARE IN MILLIMETERS ANGLES ±0.1°			SIZE A2	DWG NO
1:1 SCALE			FILE NAME: Filter.dft	REV
2 PL ±0.02 3 PL ±0.005			SCALE	WEIGHT
				SHEET 3 OF 8

REVISION HISTORY			
REV	DESCRIPTION	DATE	APPROVED

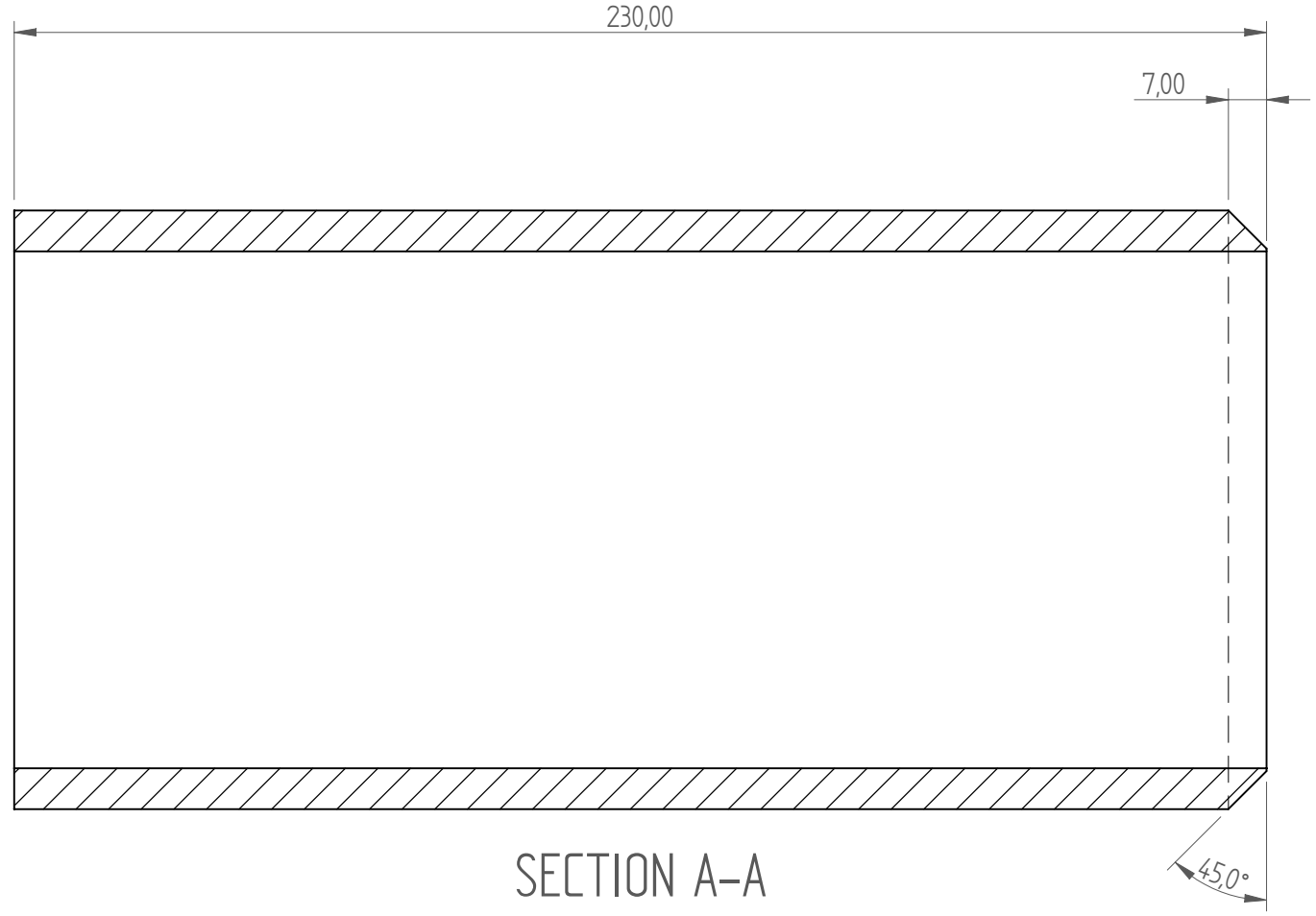
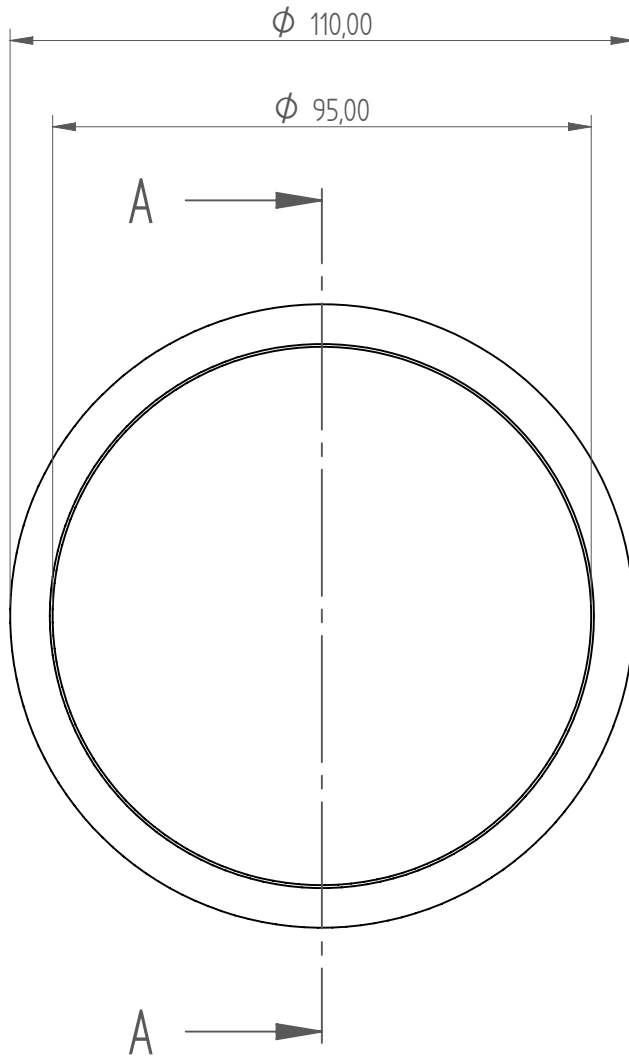

SECTION A-A

CYLINDER TUBE

DRAWN	Daan	DATE	12/24/07	PREMAC	
APPROVED				PRECISION MACHINE MANUFACTURERS (PTY)LTD.	
MATERIAL				TITLE Filter	
TREATMENT					
UNLESS OTHERWISE SPECIFIED DIMENSIONS ARE IN MILLIMETERS ANGLES $\pm 0,1^\circ$				SIZE A2	DWG NO
2 PL $\pm 0,02$ 3 PL $\pm 0,005$				FILE NAME: Filter.dft	REV
SCALE:		WEIGHT:		SHEET 4 OF 8	

REVISION HISTORY			
REV	DESCRIPTION	DATE	APPROVED

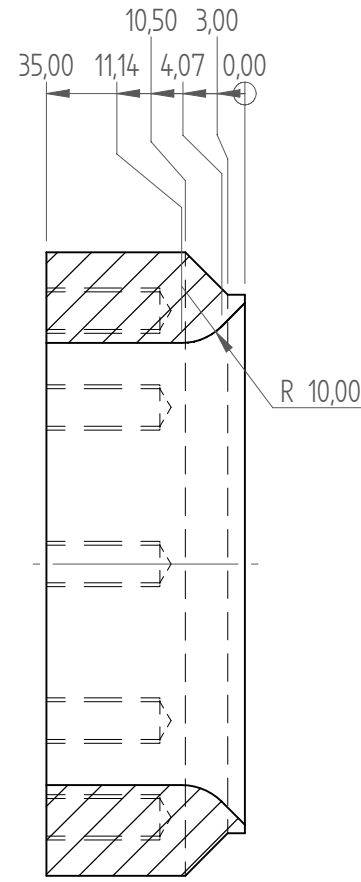
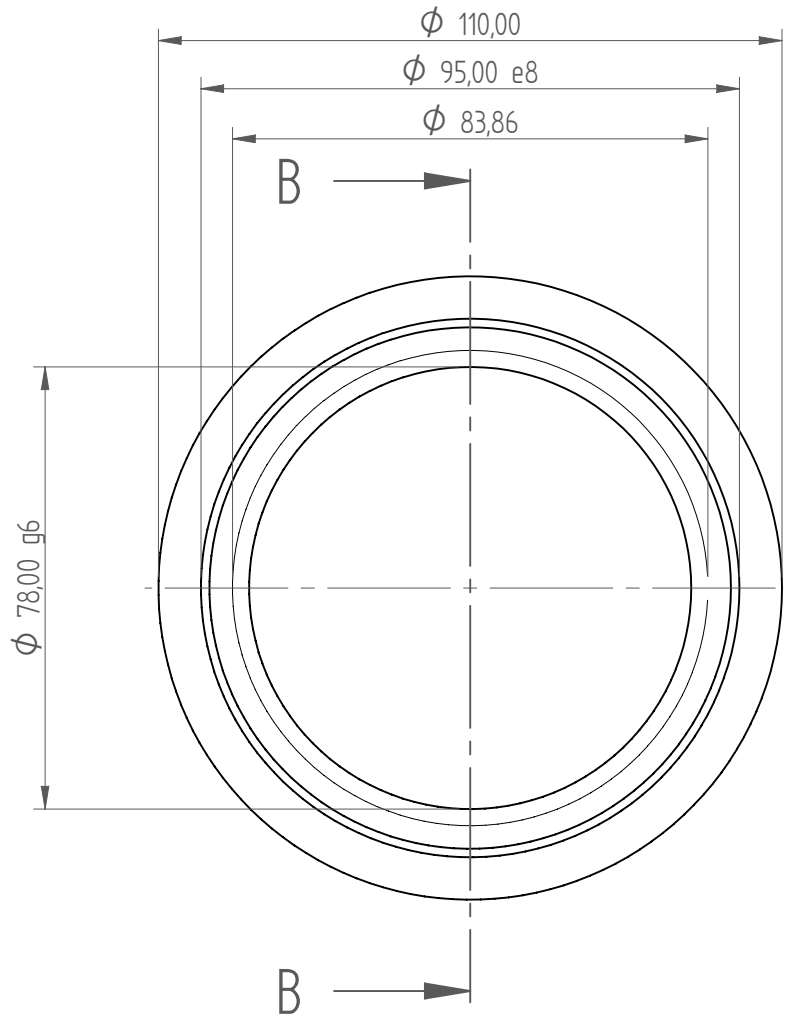

SECTION B-B

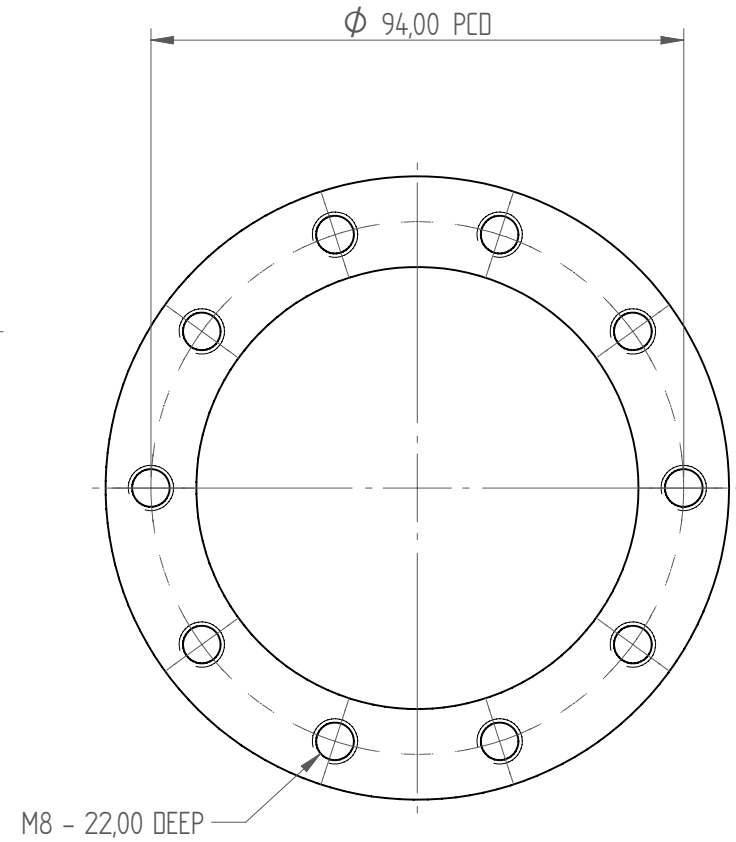

CYLINDER TUBE RING

DRAWN	NAME	DATE	PREMAC	
APPROVED	Dan	12/24/07	PRECISION MACHINE MANUFACTURERS (PTY)LTD.	
MATERIAL			TITLE	
TREATMENT			Filter	
UNLESS OTHERWISE SPECIFIED DIMENSIONS ARE IN MILLIMETERS ANGLES $\pm 0,1^\circ$			SIZE A2	DWG NO
2 PL $\pm 0,02$ 3 PL $\pm 0,005$			FILE NAME: Filter.dft	REV
SCALE:		WEIGHT:	SHEET 5 OF 8	

REVISION HISTORY			
REV	DESCRIPTION	DATE	APPROVED

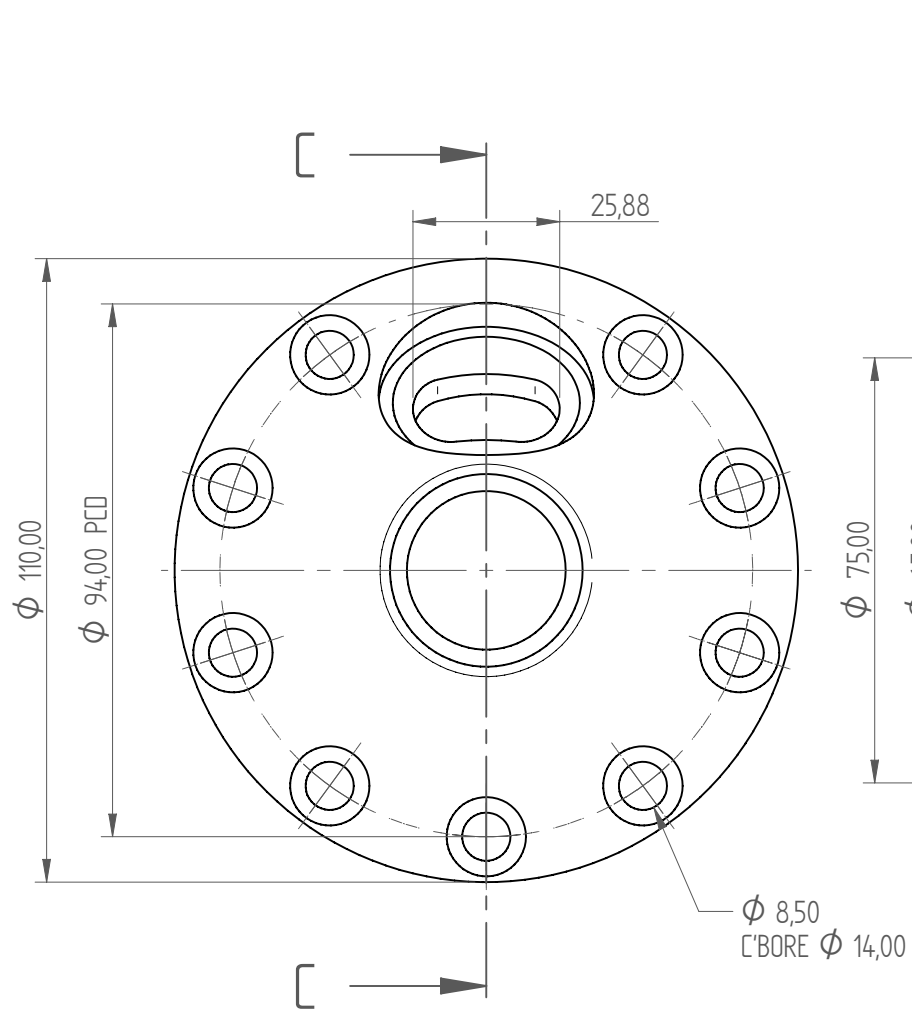

FILTER CAP

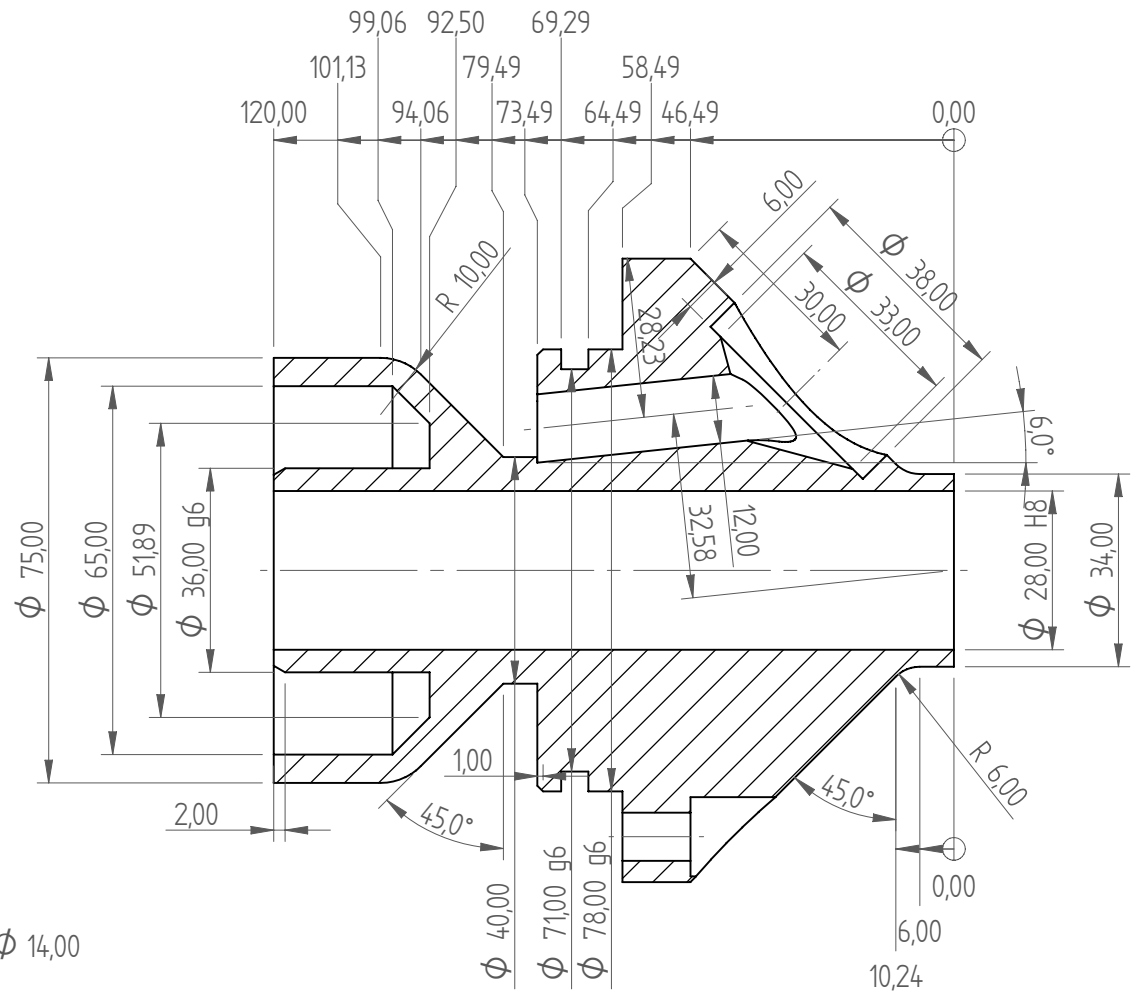

SECTION C-C

DRAWN	NAME	DATE	PREMAC	
APPROVED	Dan	12/24/07	PRECISION MACHINE MANUFACTURERS (PTY)LTD.	
MATERIAL			TITLE	Filter
TREATMENT			SIZE	DWG NO
UNLESS OTHERWISE SPECIFIED DIMENSIONS ARE IN MILLIMETERS ANGLES $\pm 0,1^\circ$			A2	REV
1:1 SCALE 2 PL $\pm 0,02$ 3 PL $\pm 0,005$			FILE NAME: Filter.dft	
SCALE:		WEIGHT:	SHEET 6 OF 8	

REVISION HISTORY			
REV	DESCRIPTION	DATE	APPROVED

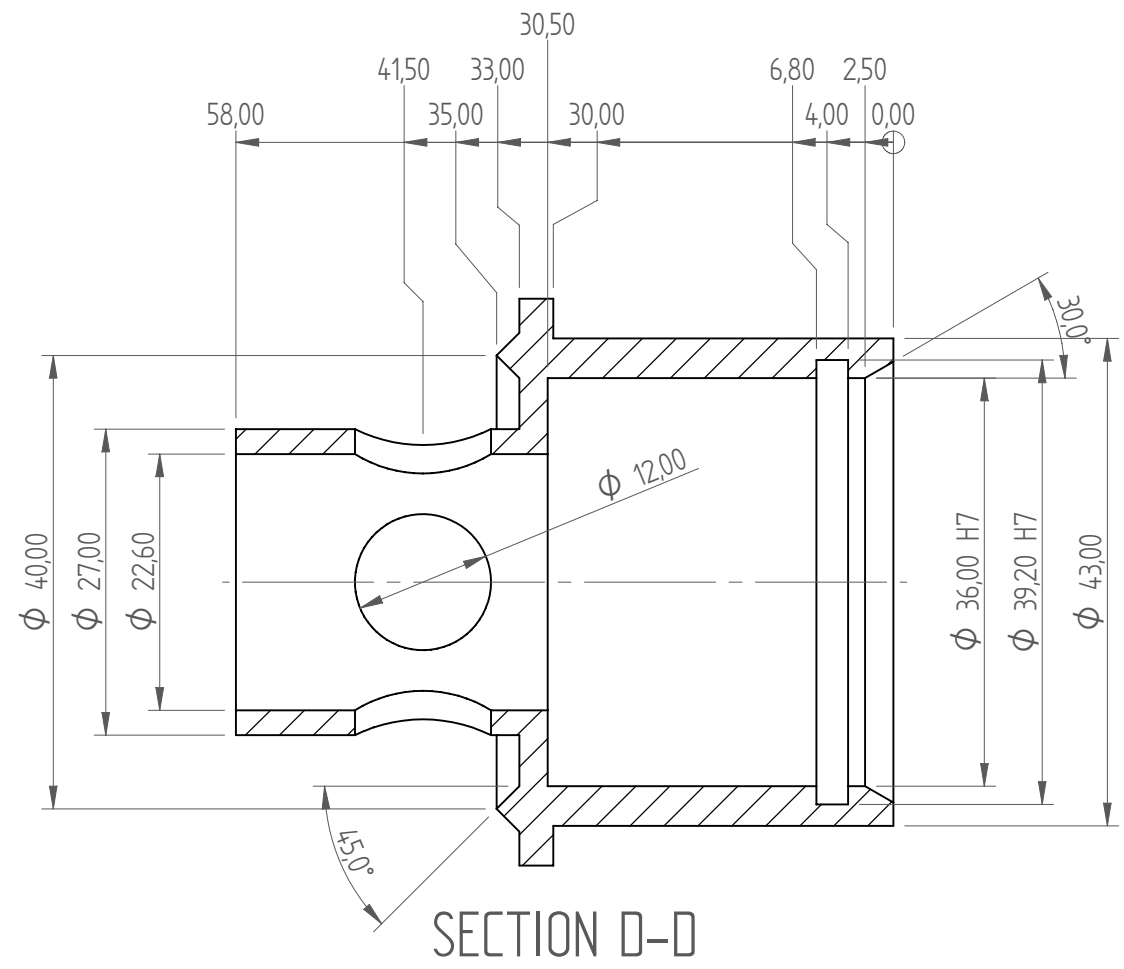
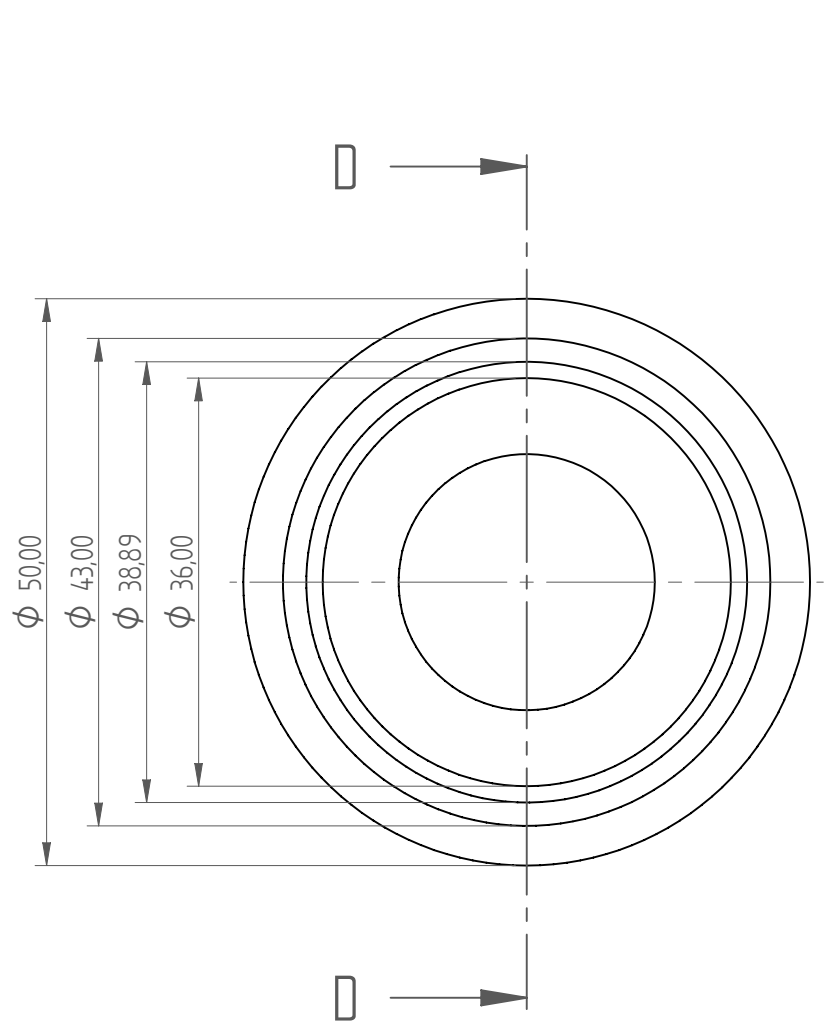

ELEMENT GUIDE

DRAWN	NAME	DATE	PREMAC	
APPROVED	Dan	12/24/07	PRECISION MACHINE MANUFACTURERS (PTY)LTD.	
MATERIAL			TITLE	
TREATMENT			Filter	
UNLESS OTHERWISE SPECIFIED DIMENSIONS ARE IN MILLIMETERS ANGLES $\pm 0,1^\circ$			SIZE A2	DWG NO
2 PL $\pm 0,02$ 3 PL $\pm 0,005$			FILE NAME: Filter.dff	REV
SCALE:		WEIGHT:	SHEET 7 OF 8	

REVISION HISTORY			
REV	DESCRIPTION	DATE	APPROVED

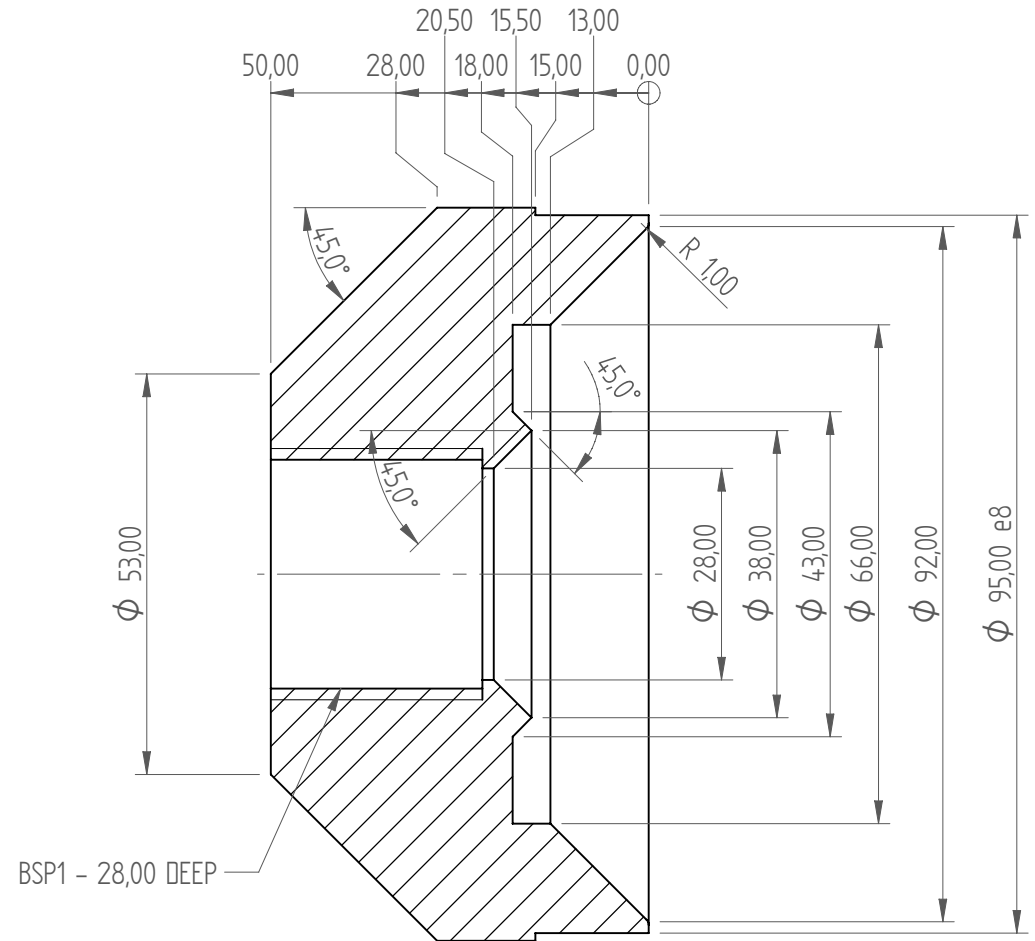
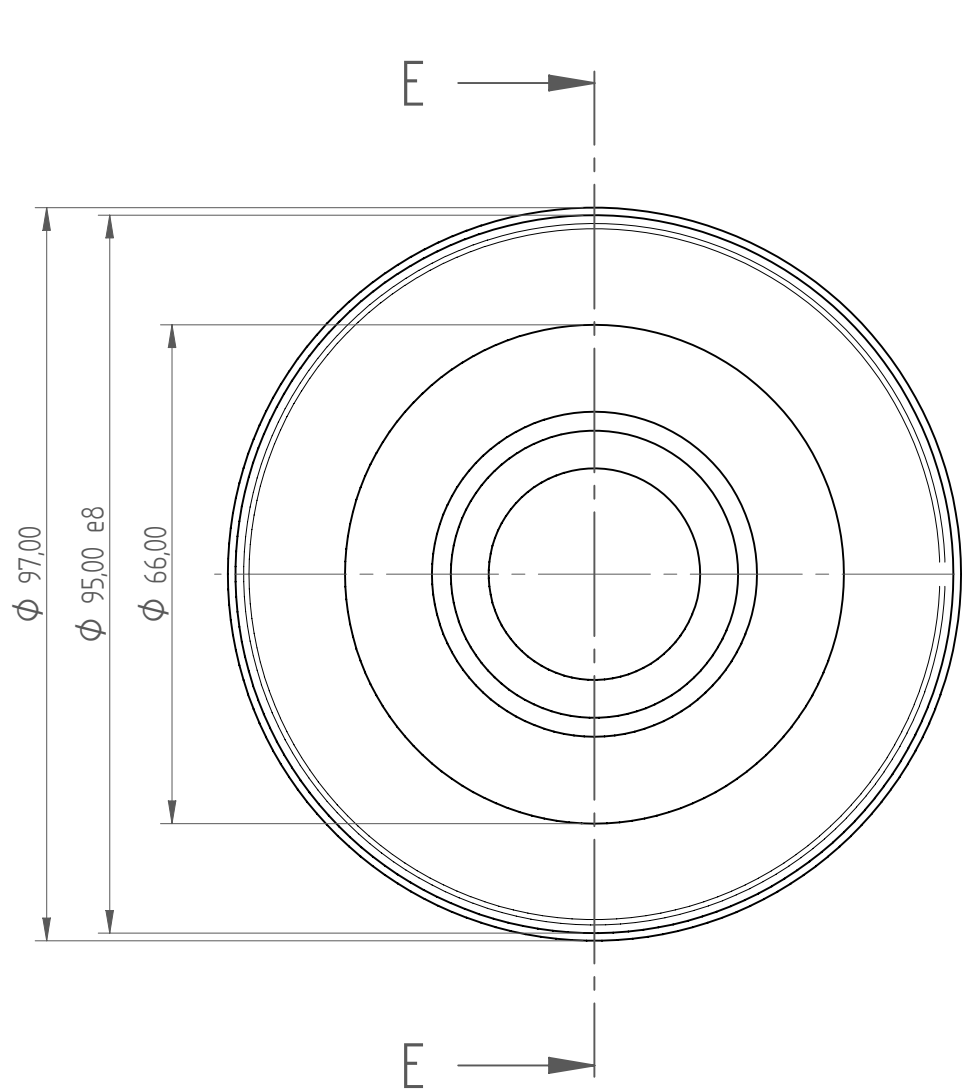

SECTION E-E

FILTER END CAP

DRAWN	NAME	DATE	PREMAC	
APPROVED	Dan	12/24/07	PRECISION MACHINE MANUFACTURERS (PTY)LTD.	
MATERIAL			TITLE	
TREATMENT			Filter	
UNLESS OTHERWISE SPECIFIED DIMENSIONS ARE IN MILLIMETERS ANGLES $\pm 0,1^\circ$			SIZE	DWG NO
1:1 UNLESS SHOWN OTHERWISE			A2	
2 PL $\pm 0,02$ 3 PL $\pm 0,005$			FILE NAME:	REV
			Filter.dft	
SCALE:		WEIGHT:	SHEET 8 OF 8	