

REVISION HISTORY			
REV	DESCRIPTION	DATE	APPROVED

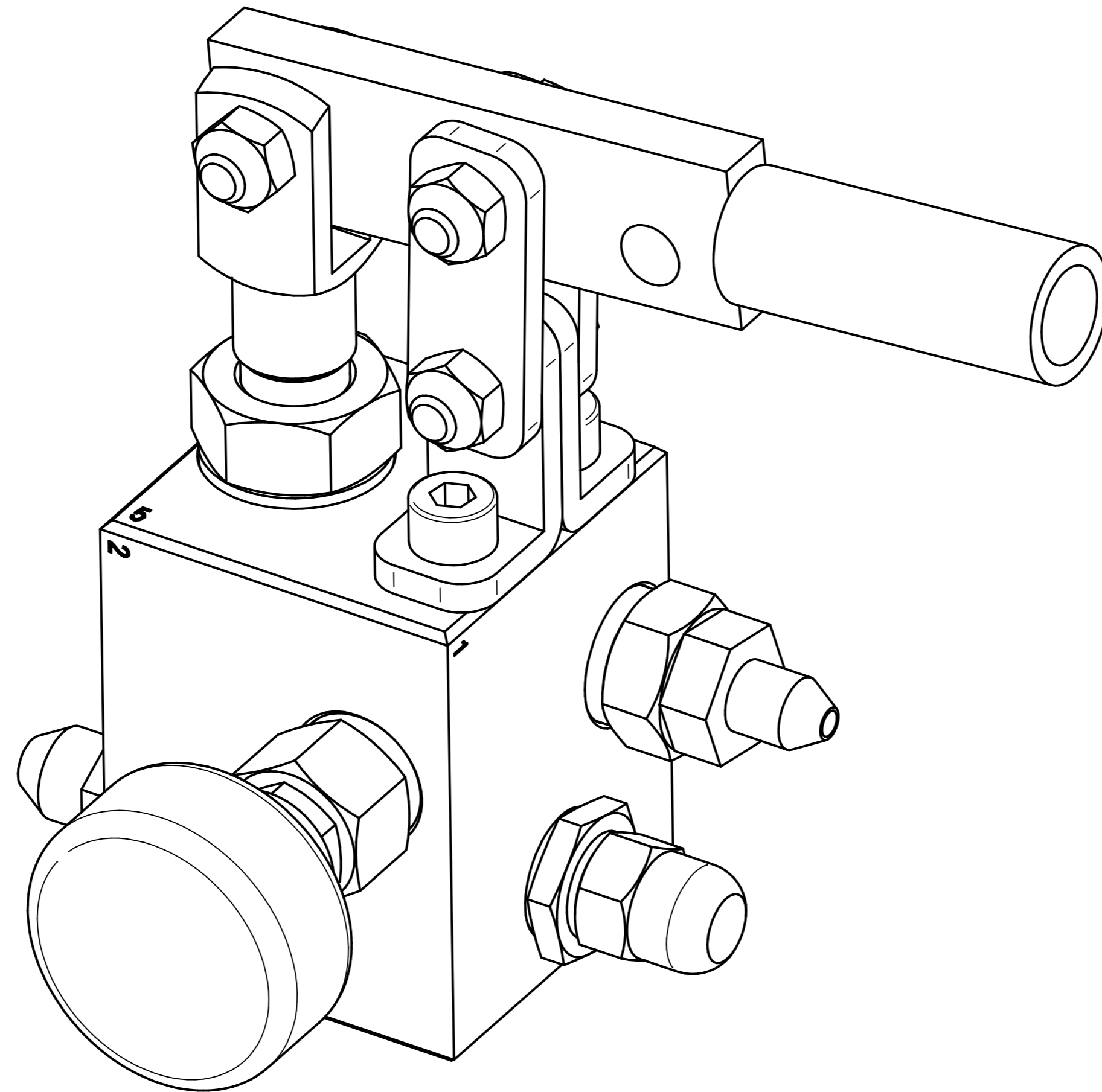

	NAME	DATE	<b>PREMAC</b>	
DRAWN	Dan	09/04/23		
APPROVED				
MATERIAL				
TREATMENT			TITLE	
UNLESS OTHERWISE SPECIFIED DIMENSIONS ARE IN MILLIMETERS			SIZE A4	DWG NO
1st ANGLE ANGLES ±0.1°			FILE NAME: Hand Pump.dft	
2 PL ±0.02 3 PL ±0.005			SCALE:	WEIGHT: SHEET 1 OF 8

REVISION HISTORY			
REV	DESCRIPTION	DATE	APPROVED

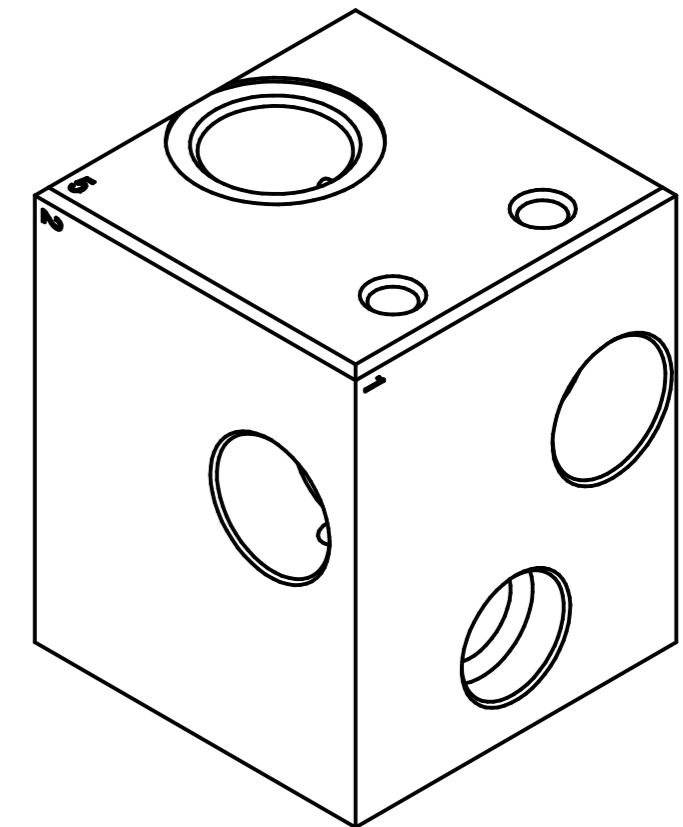
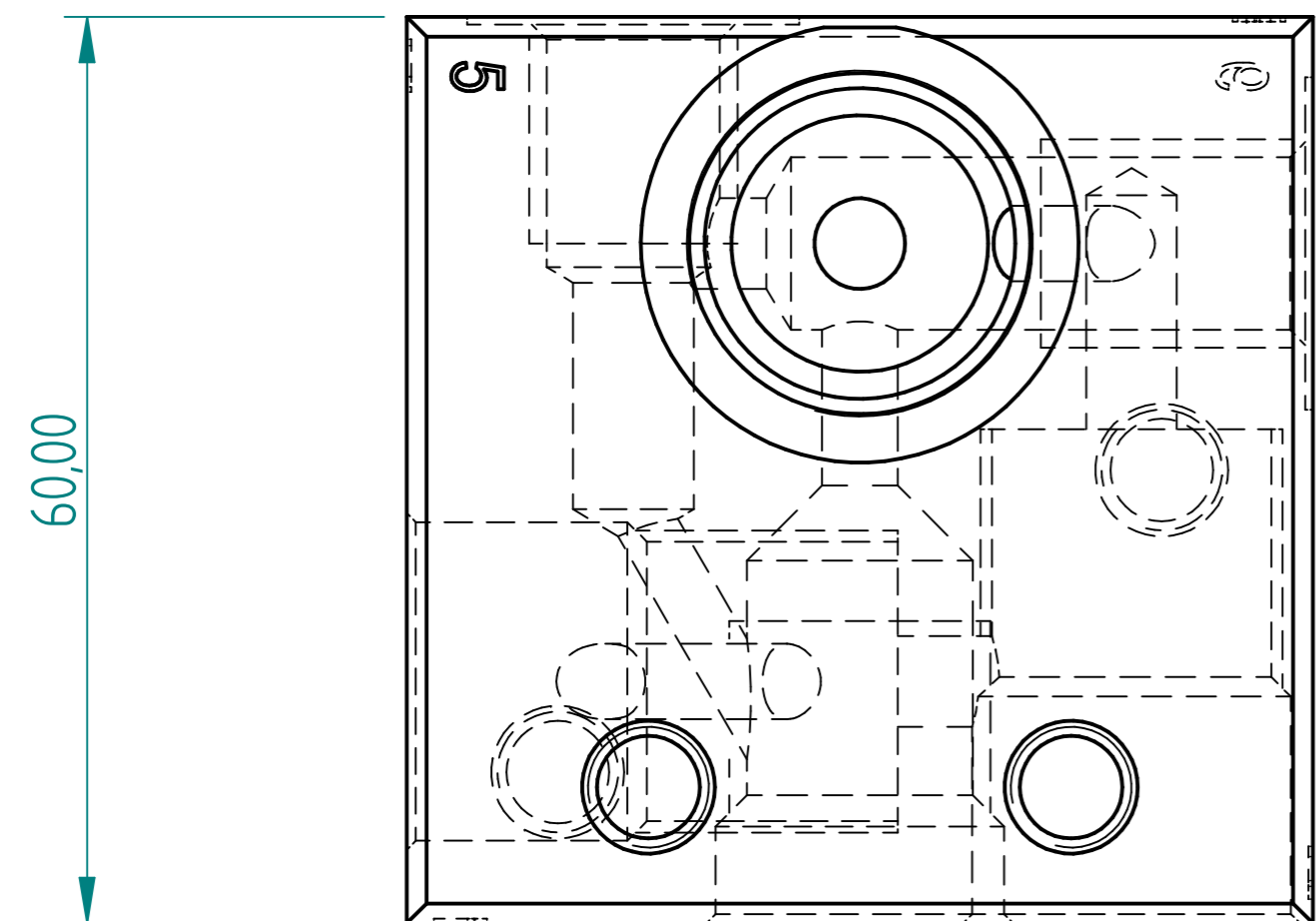
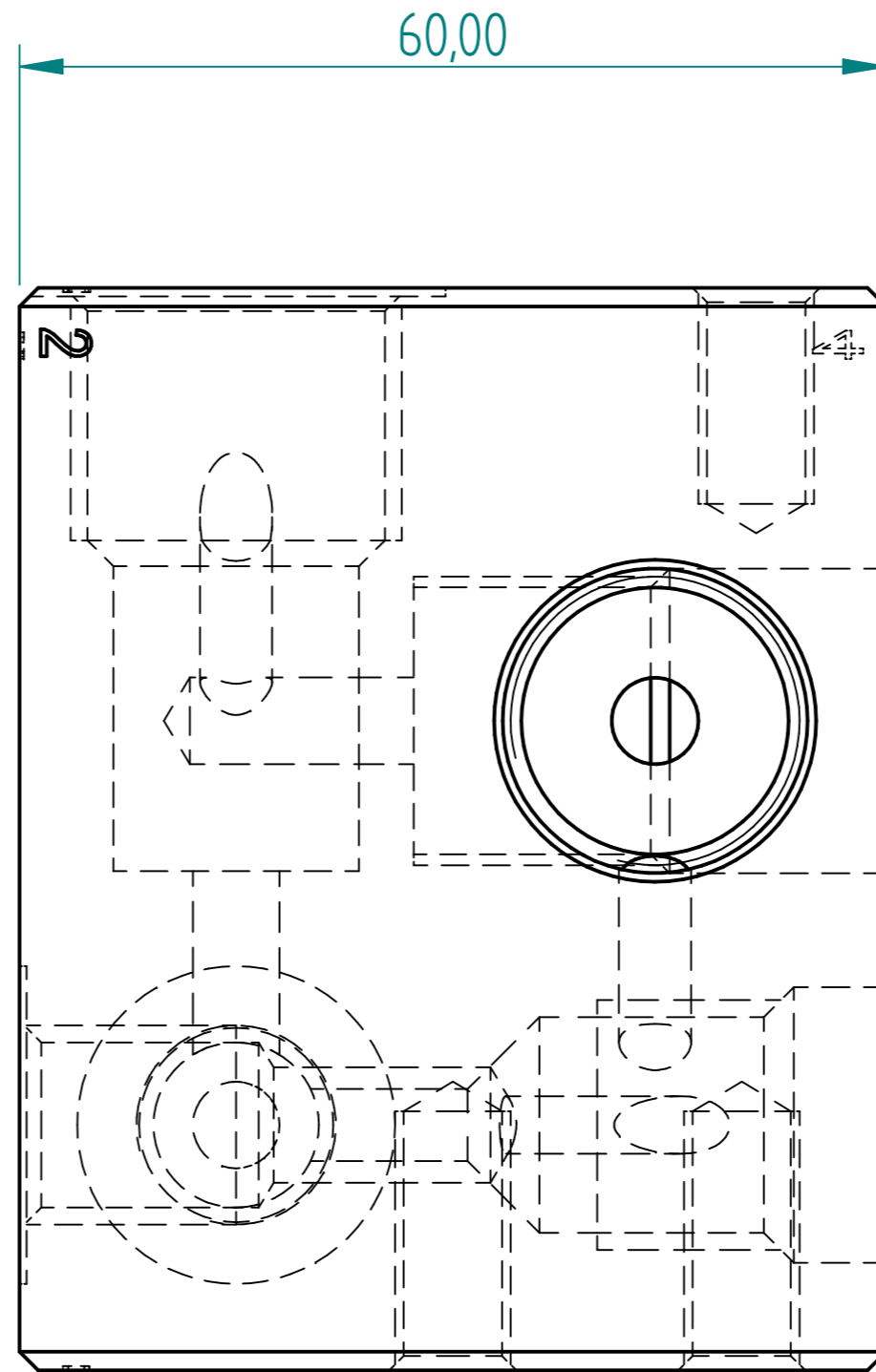
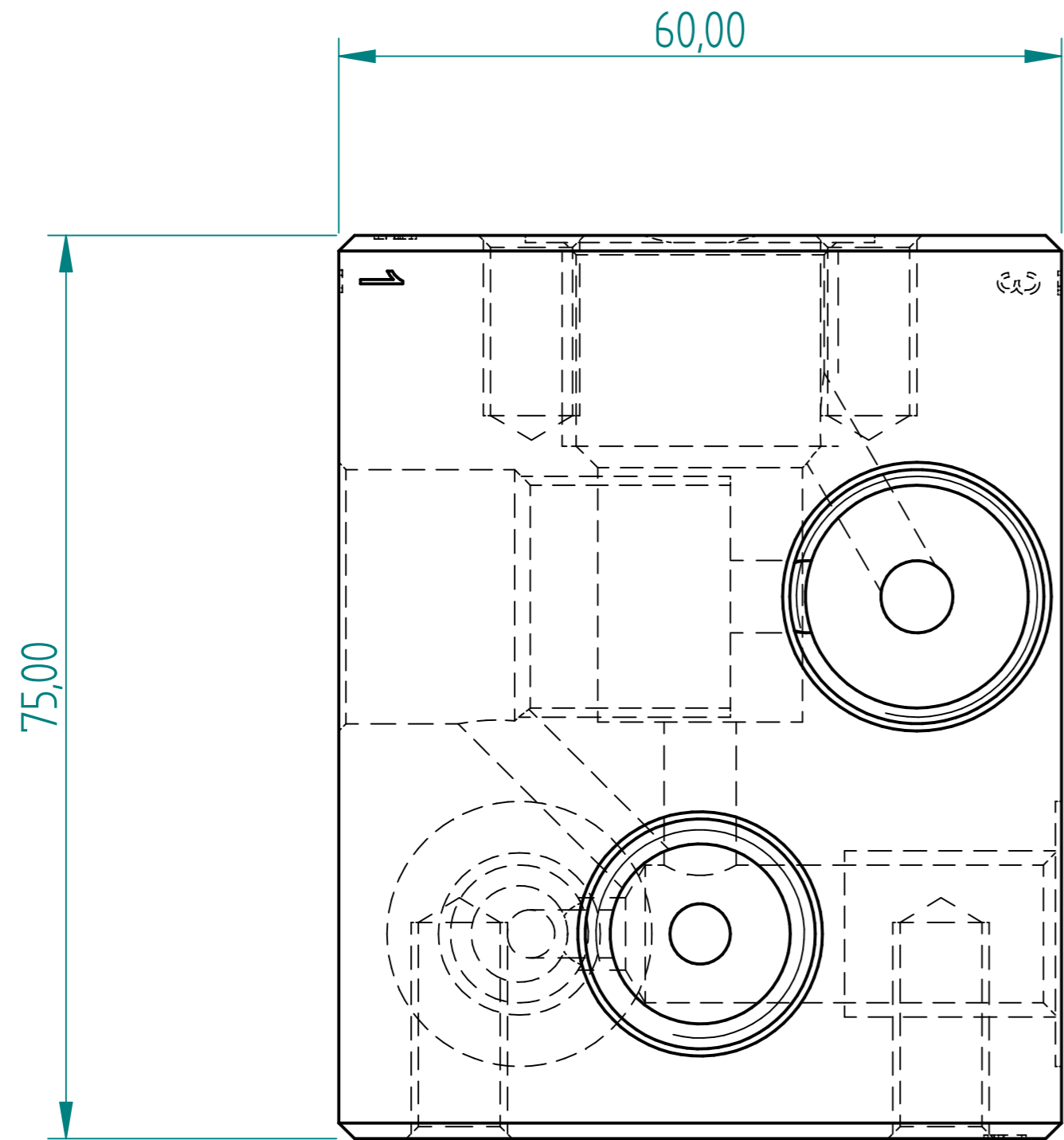

DRAWN	NAME	DATE	<b>PREMAC</b>	
APPROVED	Dan	09/04/23		
MATERIAL				
TREATMENT				
UNLESS OTHERWISE SPECIFIED DIMENSIONS ARE IN MILLIMETERS ANGLES ±0.1°			SIZE A4	DWG NO
1st ANGLE 2 PL ±0.02 3 PL ±0.005			FILE NAME: Hand Pump.dft	
			SCALE:	WEIGHT:
			SHEET 2 OF 8	

REVISION HISTORY			
REV	DESCRIPTION	DATE	APPROVED

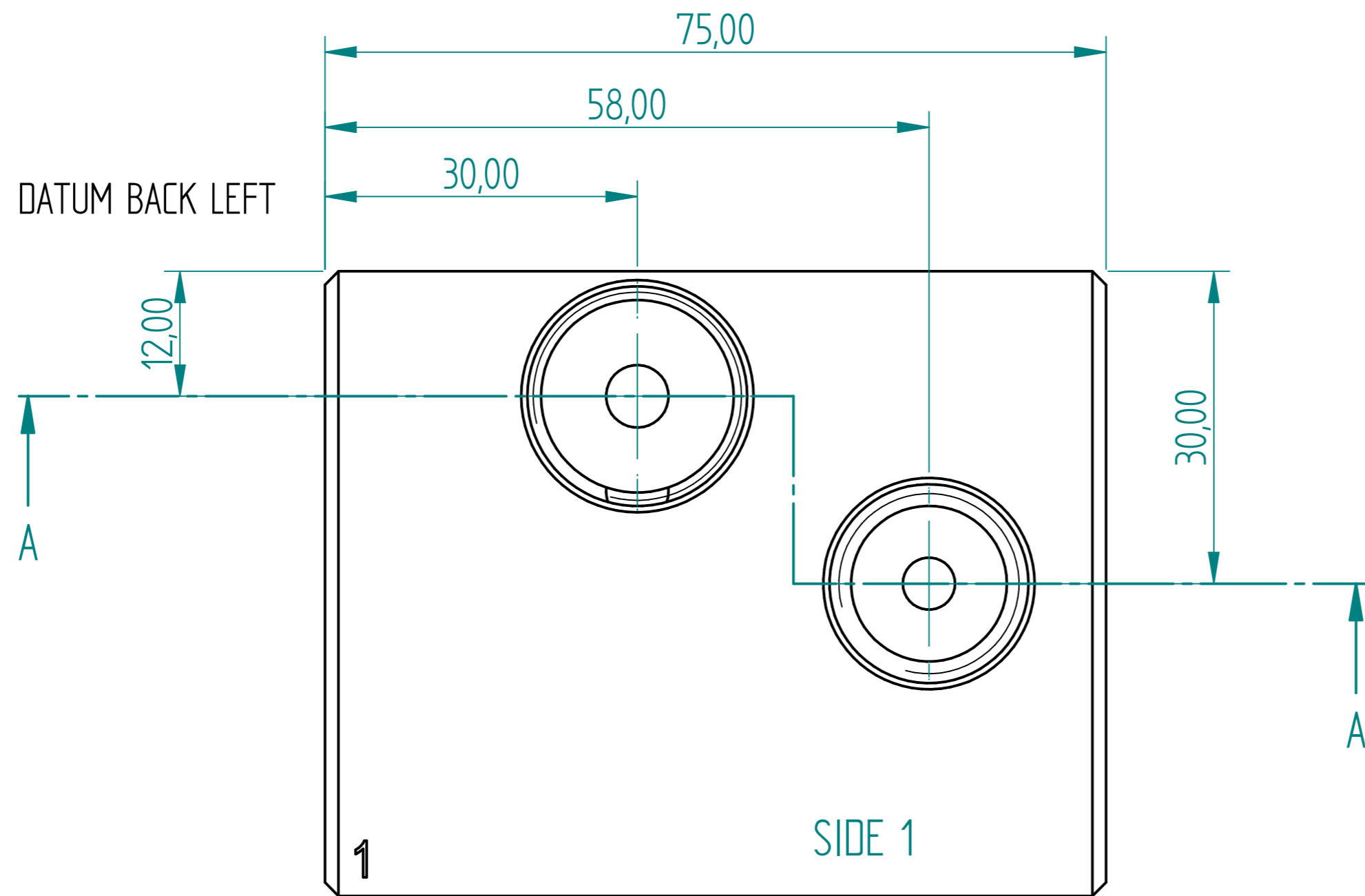

CENTRE DRILL  
D5. DRILL  
D6. DRILL  
D15. DRILL  
D12. END MILL  
CHAMFER  
THREAD 1  
THREAD 2

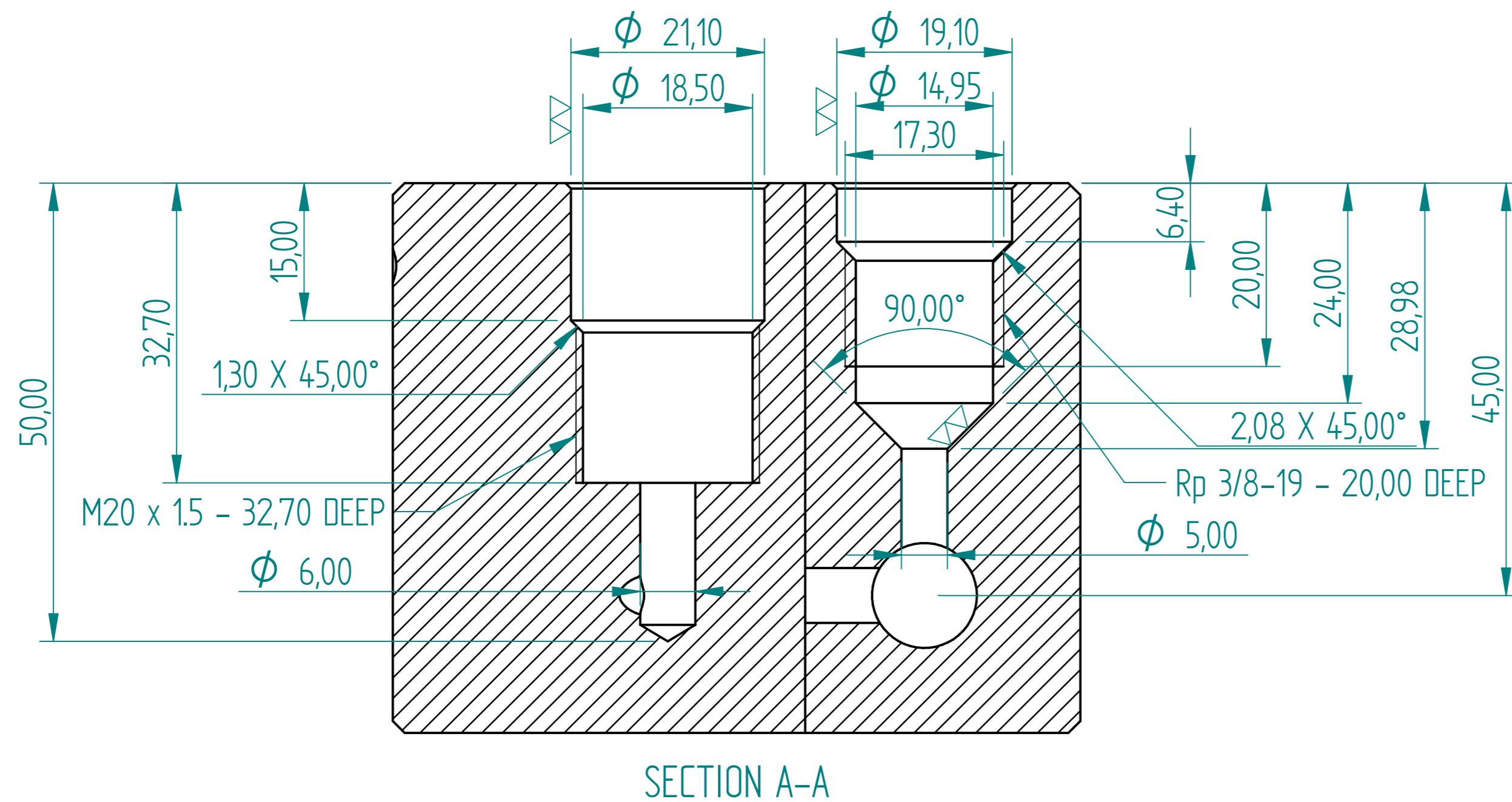

	NAME	DATE	<b>PREMAC</b>	
DRAWN	Dan	09/04/23		
APPROVED			TITLE	
MATERIAL			SIZE	DWG NO
TREATMENT			A4	
UNLESS OTHERWISE SPECIFIED DIMENSIONS ARE IN MILLIMETERS			1st ANGLE	REV
2 PL ±0.02 3 PL ±0.005			FILE NAME: Hand Pump.dft	
SCALE:	WEIGHT:	SHEET 3 OF 8		

REVISION HISTORY			
REV	DESCRIPTION	DATE	APPROVED

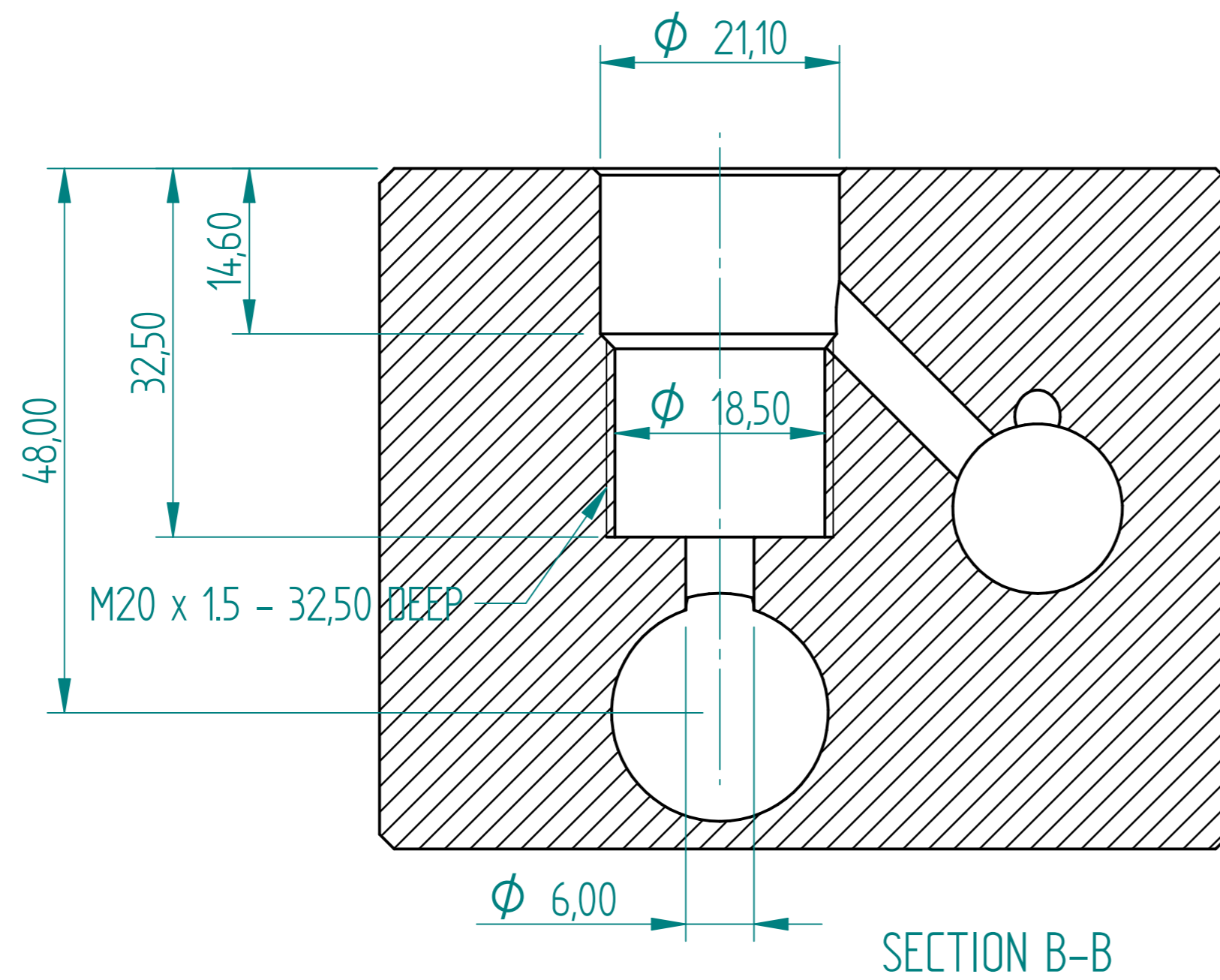
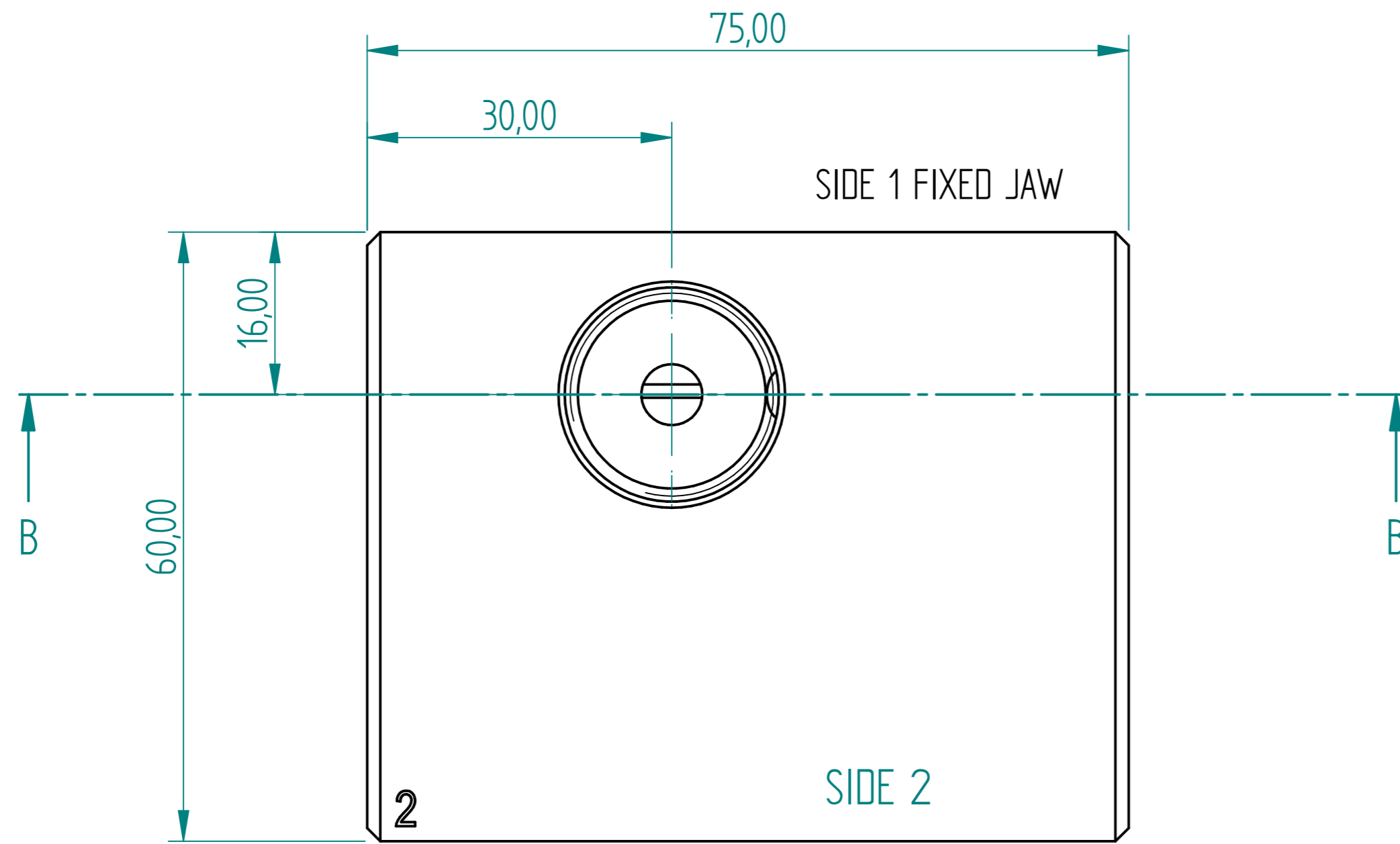

	NAME	DATE	<b>PREMAC</b>	
DRAWN	Dan	09/04/23		
APPROVED			TITLE	
MATERIAL				
TREATMENT				
UNLESS OTHERWISE SPECIFIED DIMENSIONS ARE IN MILLIMETERS			SIZE A4	DWG NO
1 <sup>ST</sup> ANGLE ANGLES ±0.1°			REV	
2 PL ±0.02 3 PL ±0.005			FILE NAME: Hand Pump.dft	
SCALE:		WEIGHT:	SHEET 4 OF 8	

REVISION HISTORY			
REV	DESCRIPTION	DATE	APPROVED

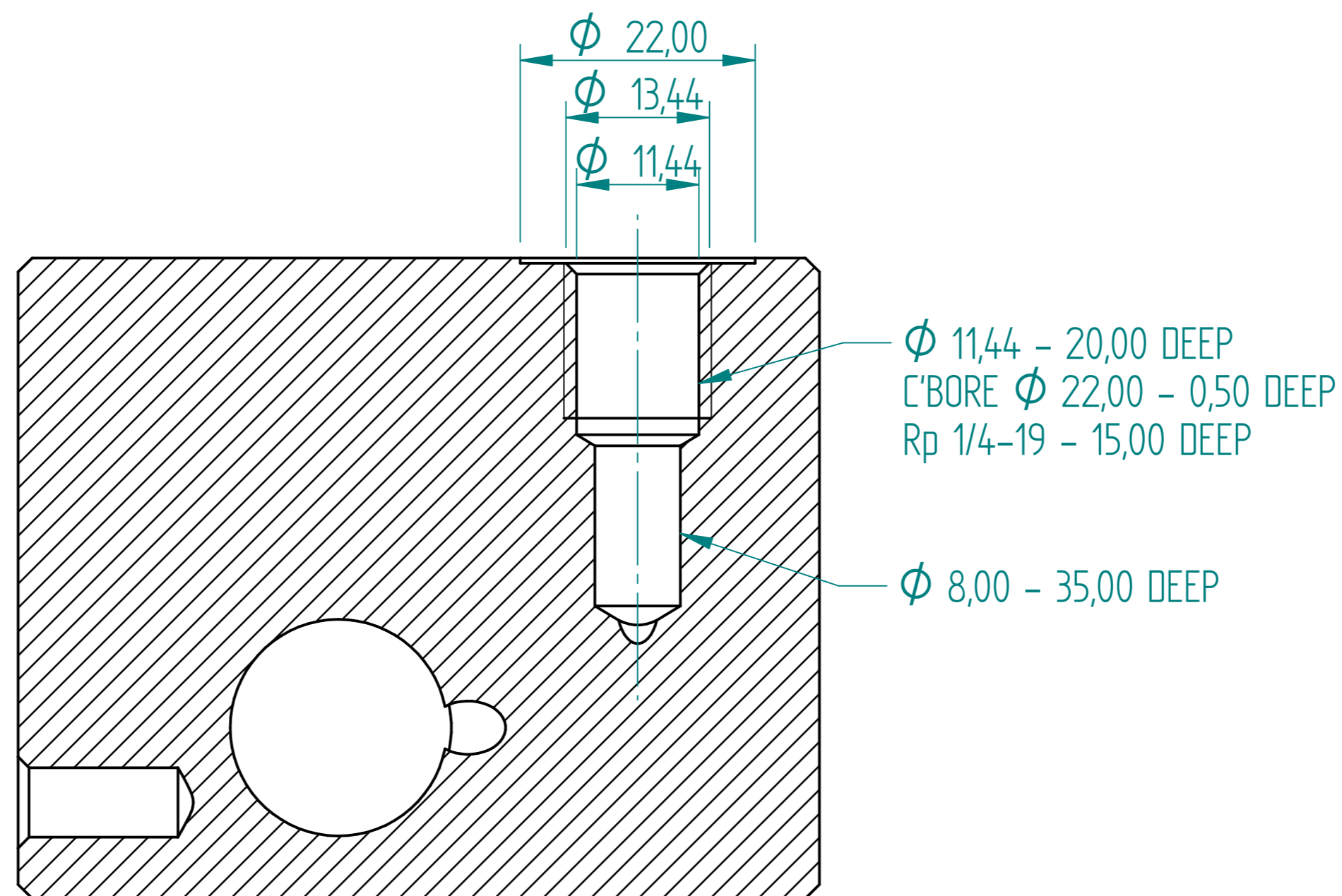
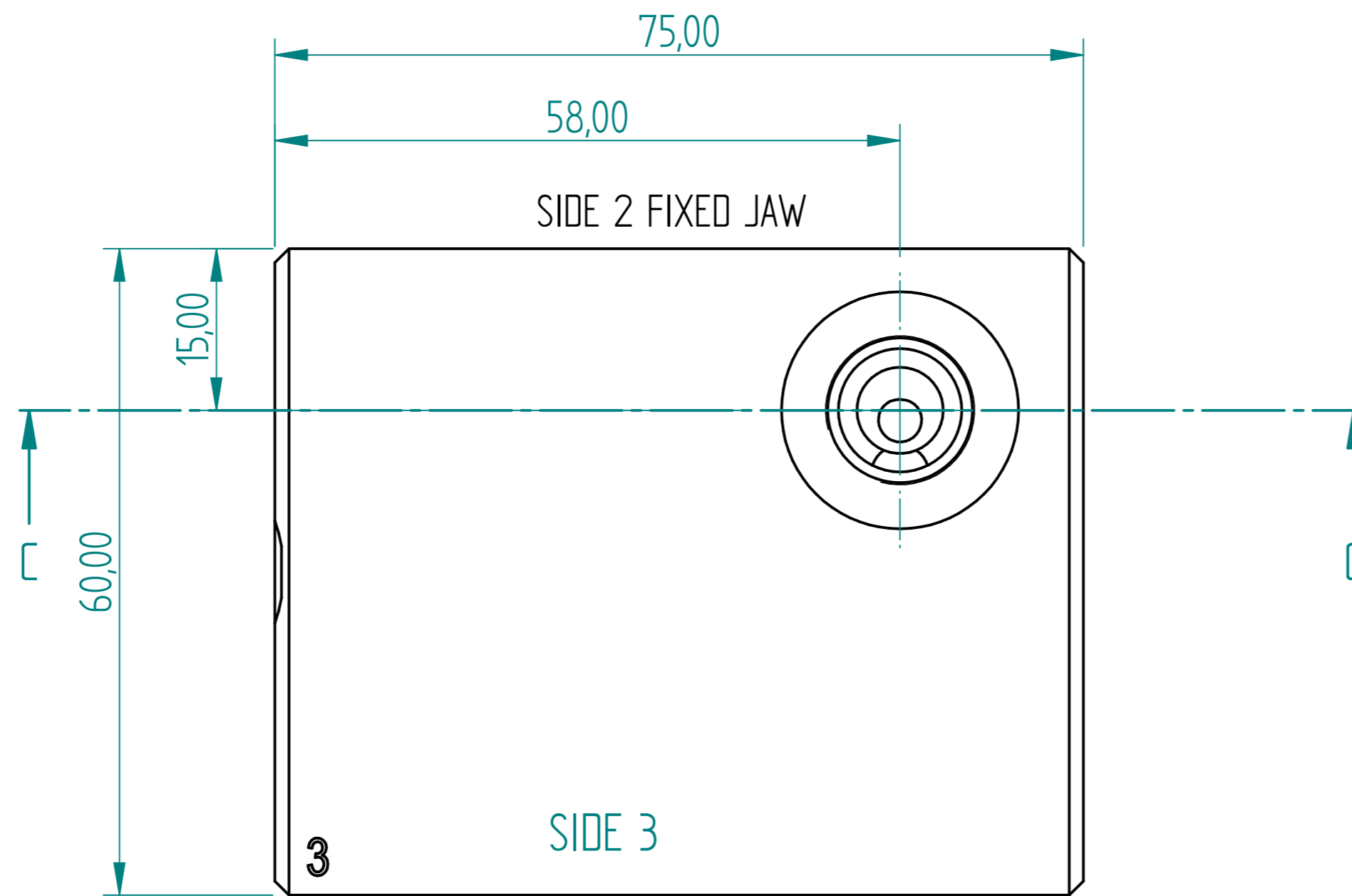

SECTION C-C

	NAME	DATE	<b>PREMAC</b>	
DRAWN	Dan	09/04/23		
APPROVED			TITLE	
MATERIAL				
TREATMENT				
UNLESS OTHERWISE SPECIFIED DIMENSIONS ARE IN MILLIMETERS			SIZE A4	DWG NO
1 <sup>ST</sup> ANGLE ANGLES $\pm 0.1^\circ$			REV	
2 PL $\pm 0.02$ 3 PL $\pm 0.005$			FILE NAME: Hand Pump.dft	
SCALE:			WEIGHT:	SHEET 5 OF 8

REVISION HISTORY			
REV	DESCRIPTION	DATE	APPROVED

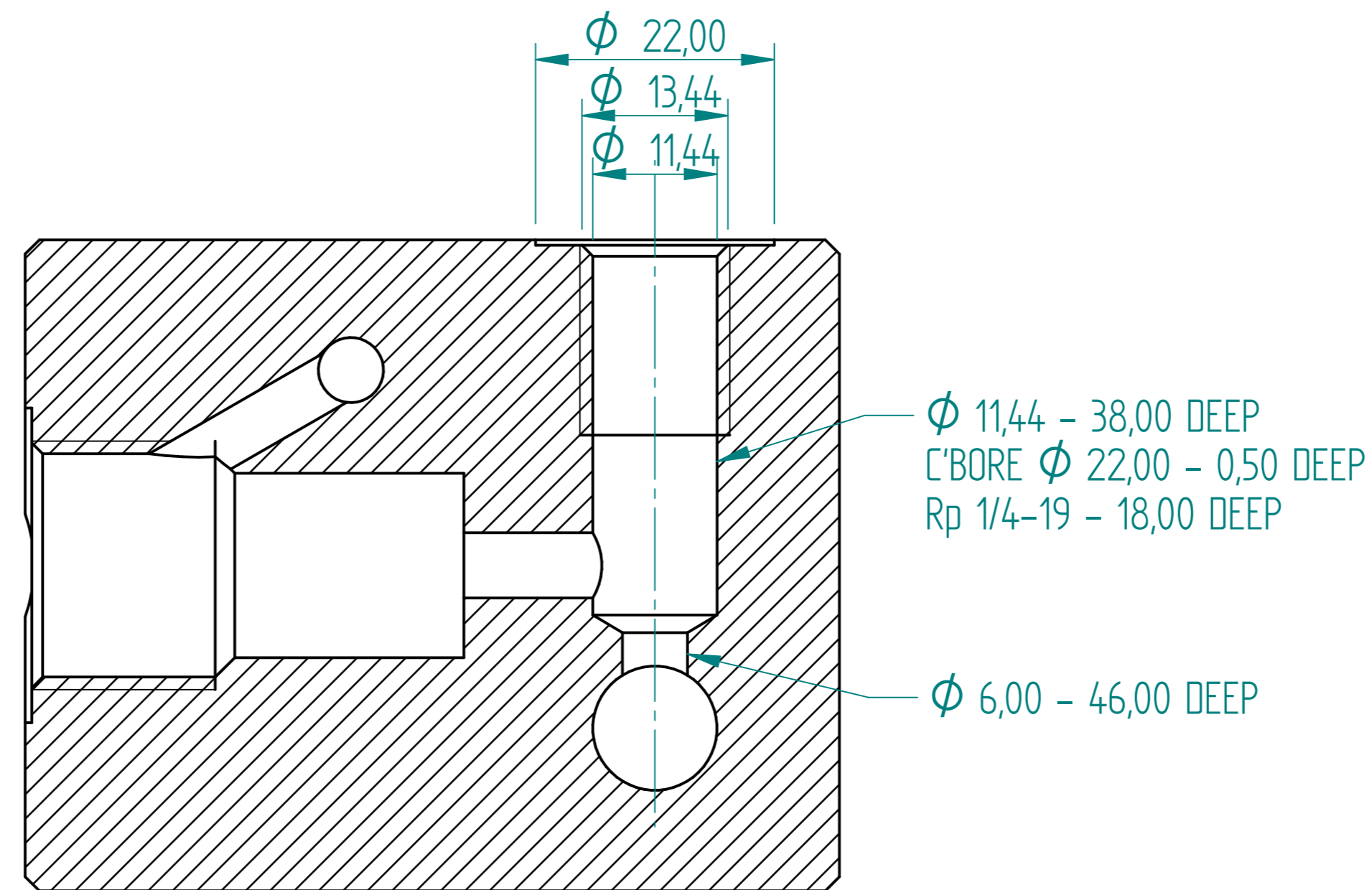
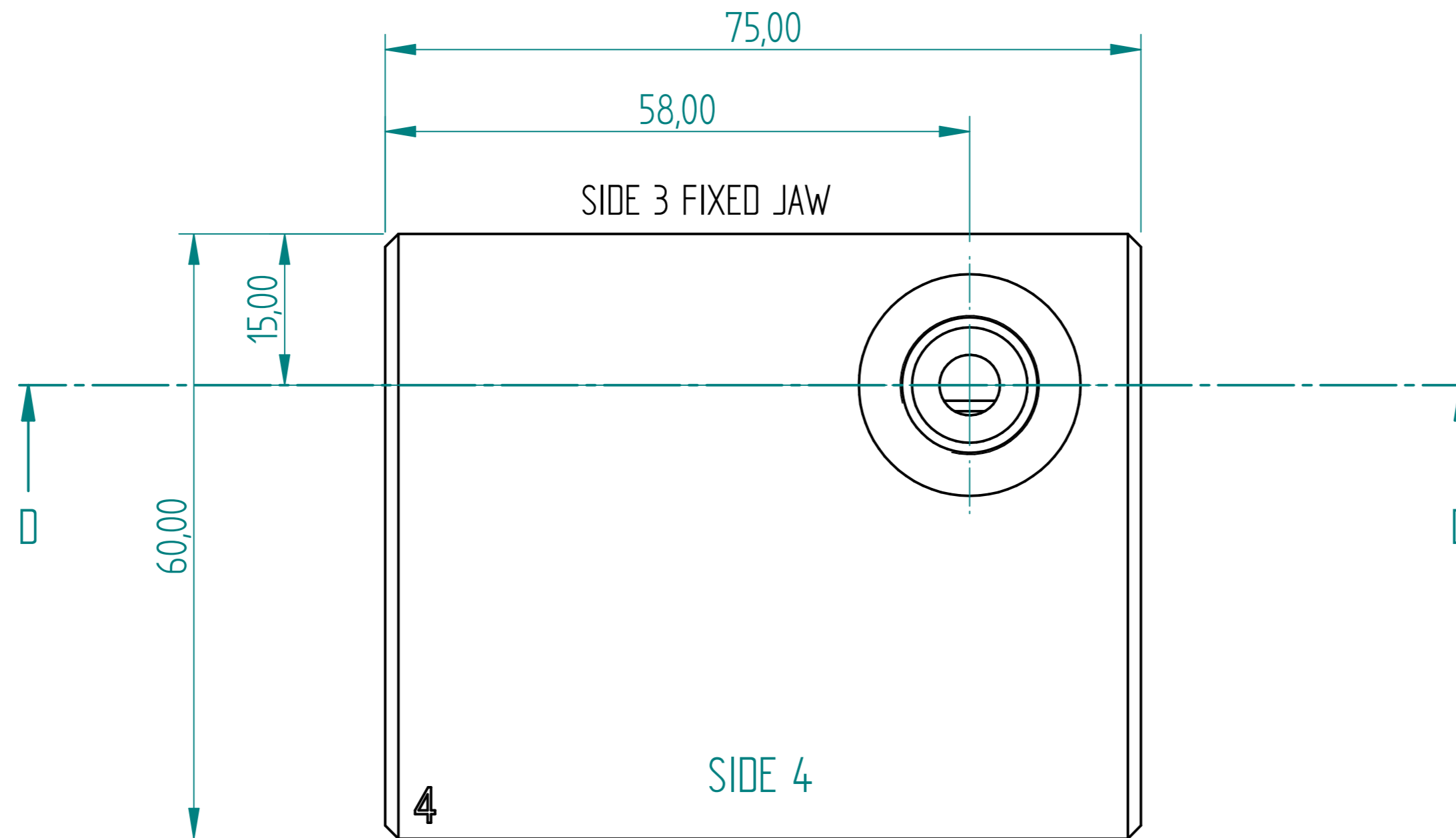

SECTION D-D

DRAWN	NAME	DATE	<b>PREMAC</b>	
APPROVED	Dan	09/04/23		
MATERIAL			TITLE	
TREATMENT			REV	
UNLESS OTHERWISE SPECIFIED DIMENSIONS ARE IN MILLIMETERS			SIZE A4	DWG NO
1st ANGLE ANGLES ±0.1°			FILE NAME: Hand Pump.dft	
2 PL ±0.02 3 PL ±0.005			SCALE:	WEIGHT: SHEET 6 OF 8

REVISION HISTORY			
REV	DESCRIPTION	DATE	APPROVED

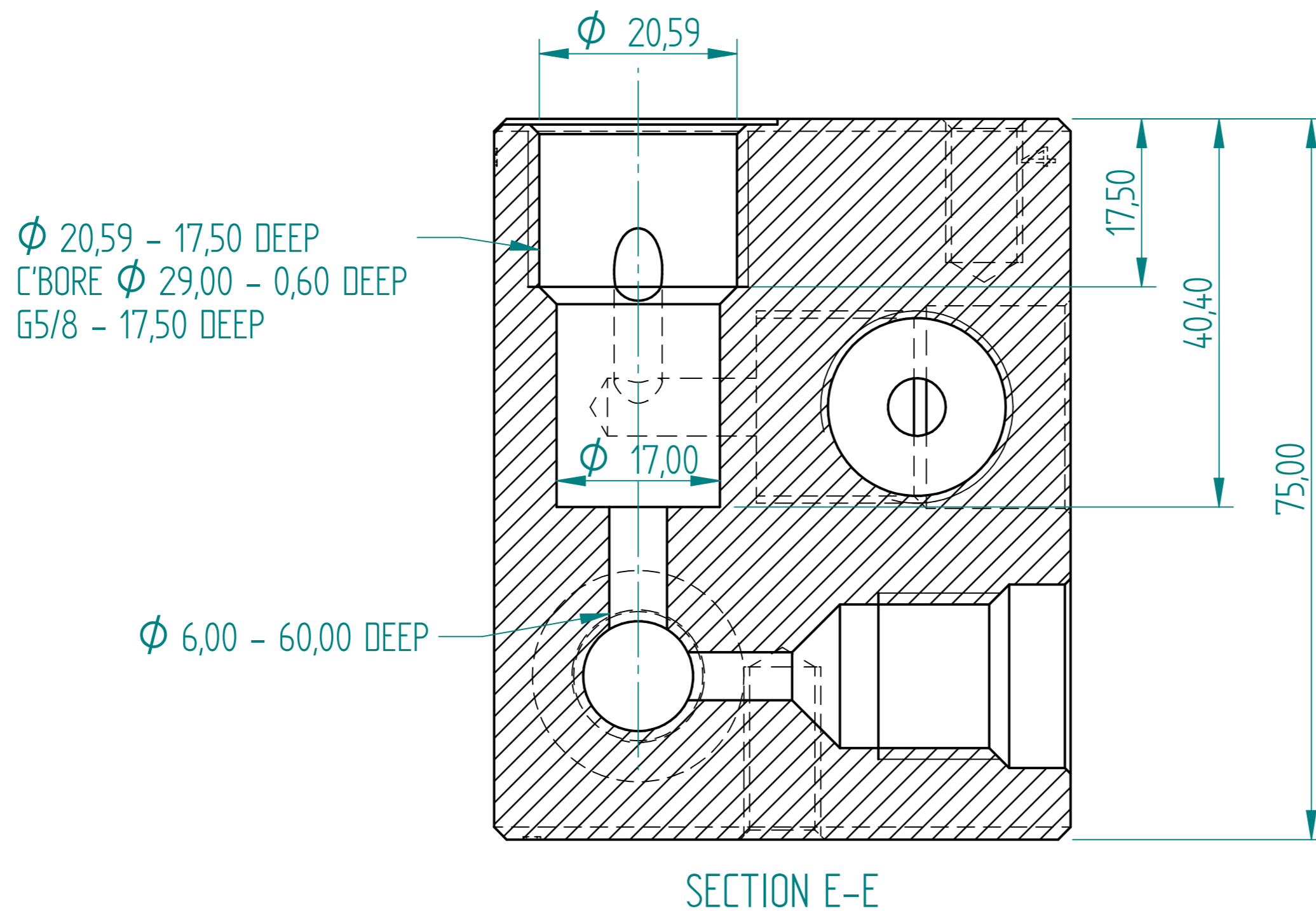
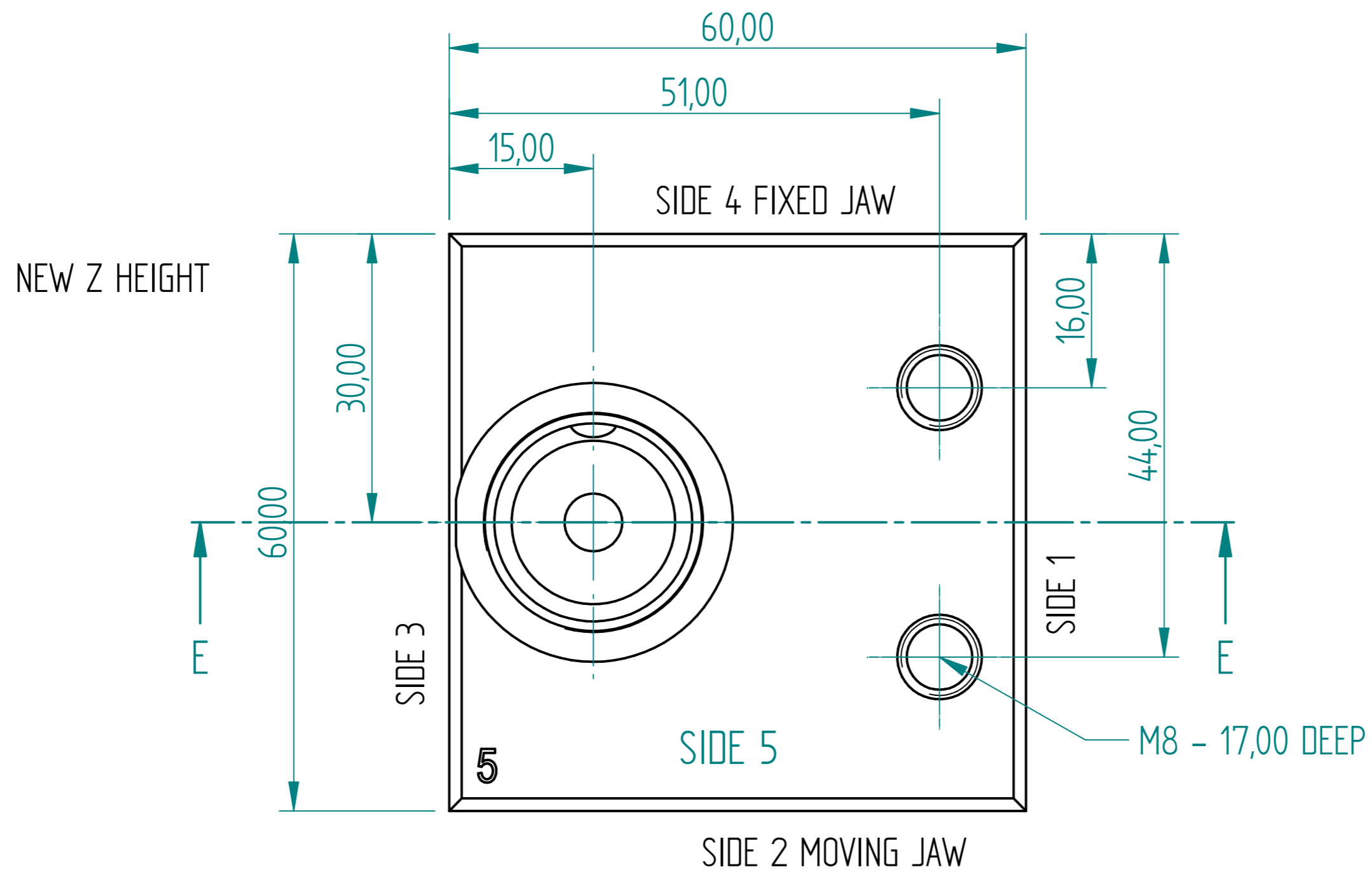

DRAWN	NAME	DATE	<b>PREMAC</b>	
APPROVED	Dan	09/04/23		
MATERIAL			TITLE	
TREATMENT			SIZE	
UNLESS OTHERWISE SPECIFIED DIMENSIONS ARE IN MILLIMETERS			A4	DWG NO
1 <sup>ST</sup> ANGLE			REV	
2 PL $\pm 0,02$ 3 PL $\pm 0,005$			FILE NAME: Hand Pump.dft	
SCALE:		WEIGHT:	SHEET 7 OF 8	

REVISION HISTORY			
REV	DESCRIPTION	DATE	APPROVED

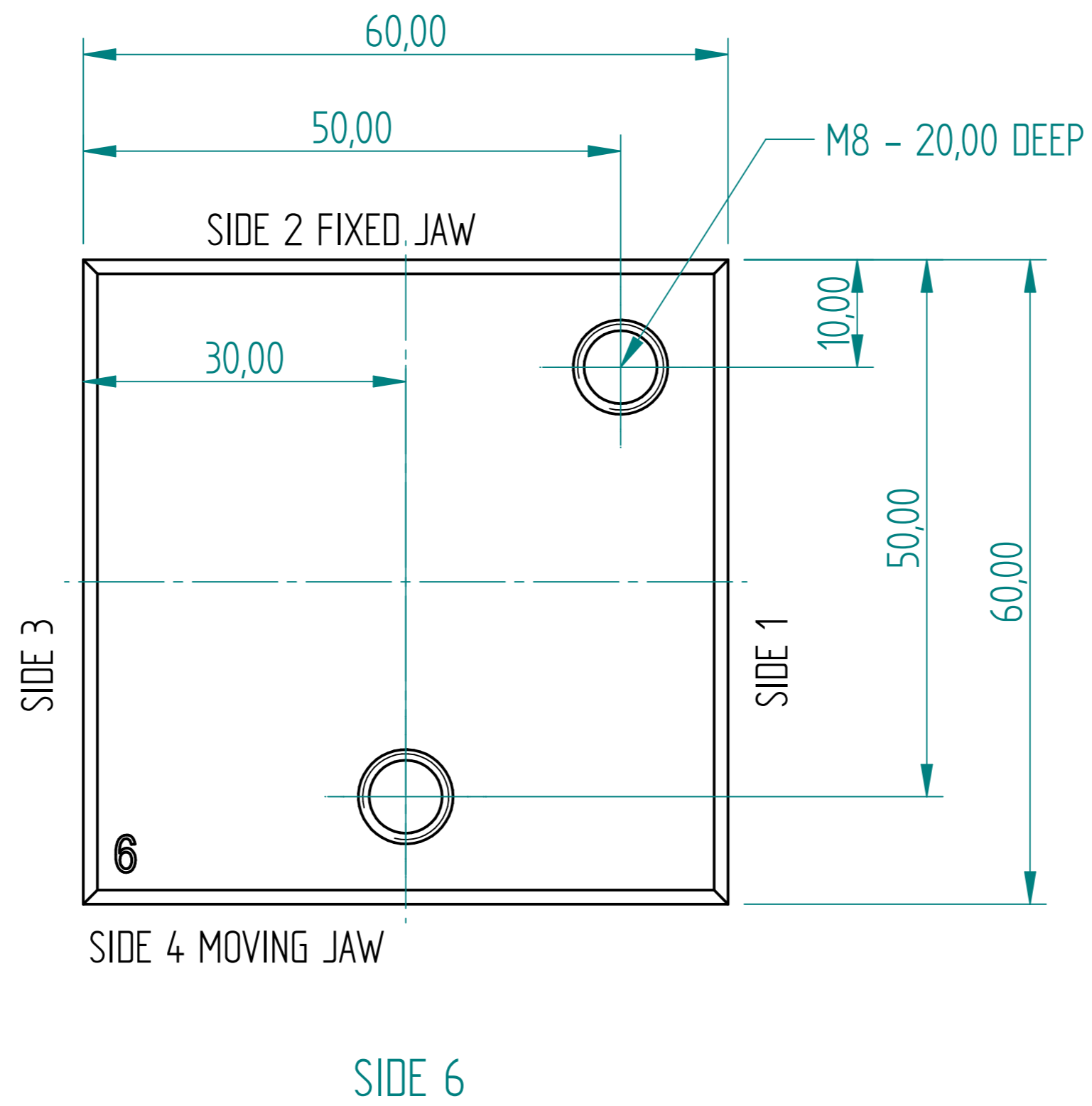

	NAME	DATE	<b>PREMAC</b>	
DRAWN	Dan	09/04/23		
APPROVED				
MATERIAL				
TREATMENT			TITLE	
UNLESS OTHERWISE SPECIFIED DIMENSIONS ARE IN MILLIMETERS			SIZE A4	DWG NO
1 <sup>ST</sup> ANGLE 			FILE NAME: Hand Pump.dft	
2 PL ±0.02 3 PL ±0.005			SCALE:	WEIGHT:
			SHEET 8 OF 8	