

REVISION HISTORY			
REV	DESCRIPTION	DATE	APPROVED

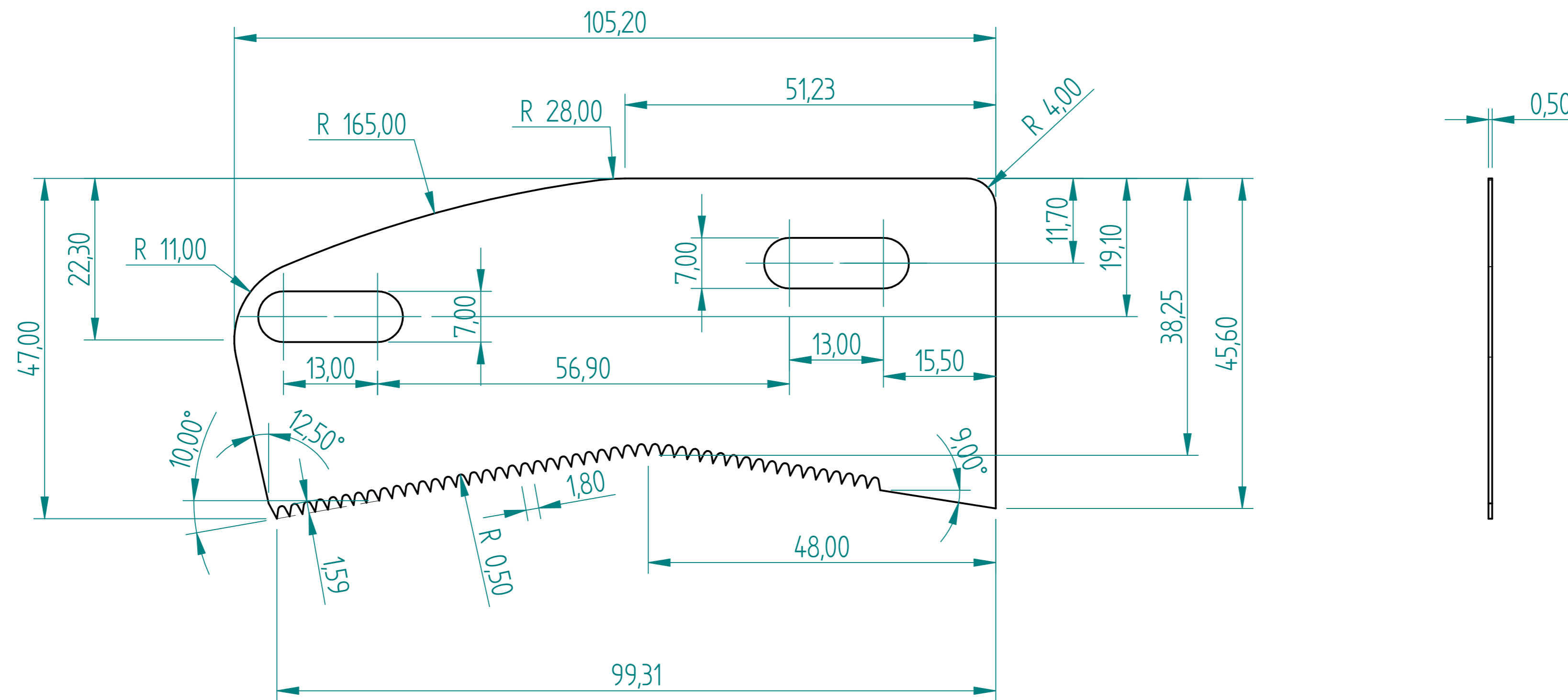

BLADE
 PROFILE CUT FROM 0.5mm SS440C SHEET
 DIMENSIONS ARE IN MILLIMETERS
 DXF FILE WILL BE PROVIDED

	NAME	DATE	AGRIGEL	
DRAWN	Dan	08/24/18		
APPROVED	D.L.G.		TITLE	
MATERIAL	SS 440c		BLADE	
TREATMENT	58 HRC		SIZE	DWG NO
UNLESS OTHERWISE SPECIFIED DIMENSIONS ARE IN MILLIMETERS			A4	
1st ANGLE ANGLES ±0.1°			FILE NAME: Blade.dxf	REV
2 PL ±0.02 3 PL ±0.005			SCALE: NTS	WEIGHT: 14 g SHEET 1 OF 2