

REVISION HISTORY			
REV	DESCRIPTION	DATE	APPROVED

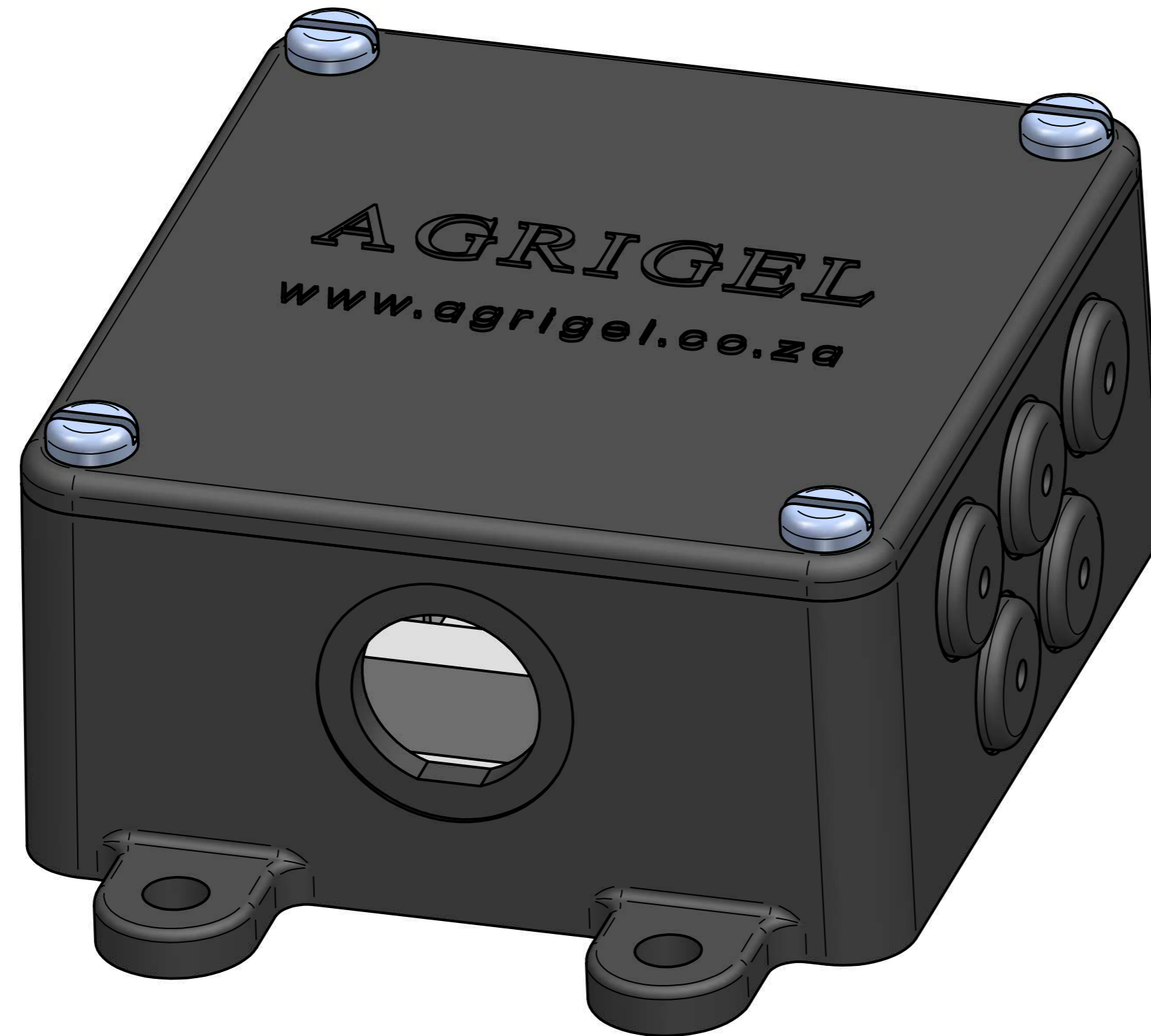

DISTRIBUTION BOX

	NAME	DATE	AGRIGEL	
DRAWN	Dan	12/09/09	TITLE	
APPROVED			Distribution Box	
MATERIAL			SIZE	DWG NO
TREATMENT			A4	DB-100
UNLESS OTHERWISE SPECIFIED DIMENSIONS ARE IN MILLIMETERS			FILE NAME:	REV
1 st ANGLE ANGLES ±0.1°			Distribution Box.dft	
2 PL ±0.02 3 PL ±0.005			SCALE:	WEIGHT:
				SHEET 1 OF 6

REVISION HISTORY			
REV	DESCRIPTION	DATE	APPROVED

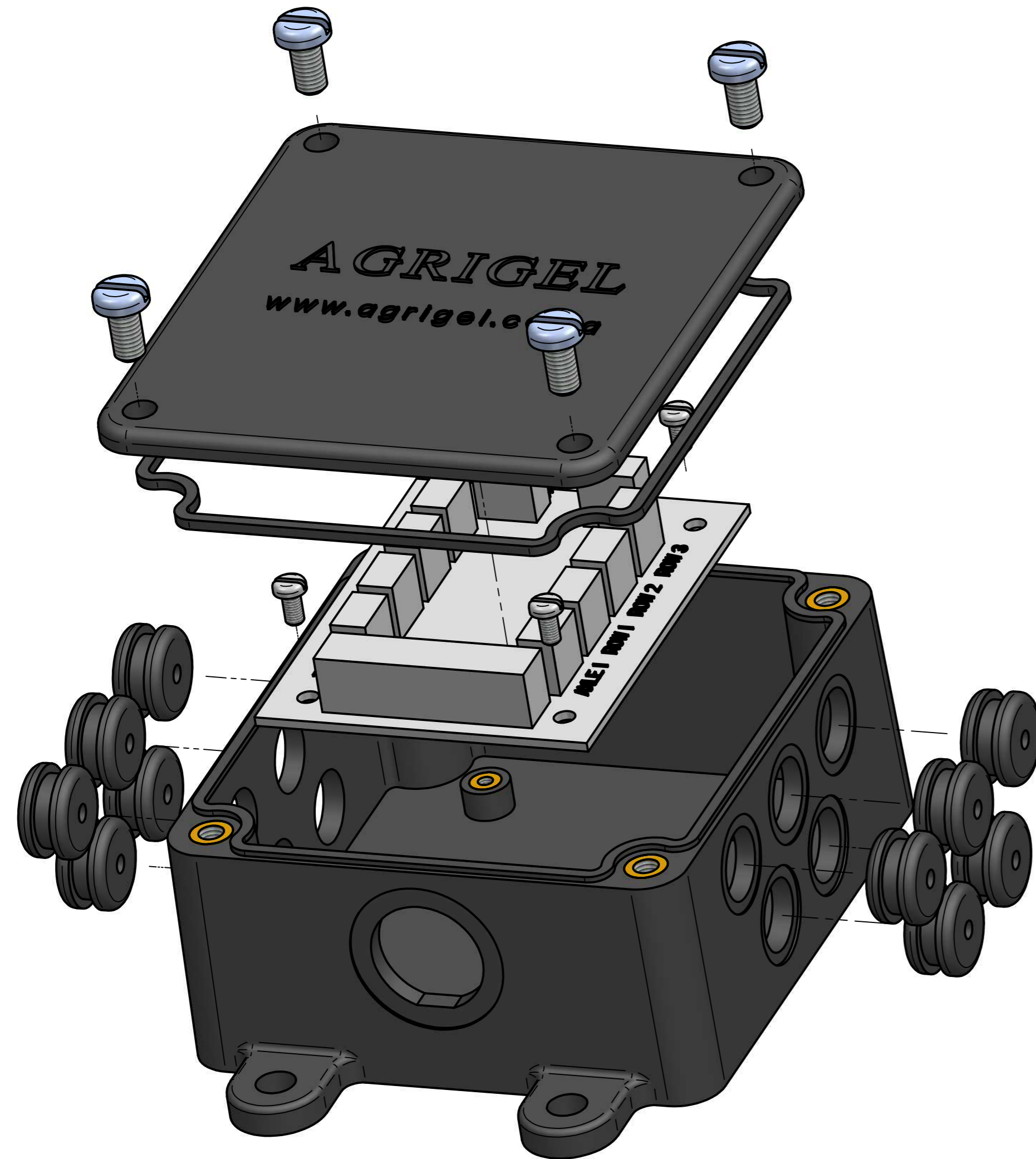

Item Number	Document Number	Title	Material	Quantity
1	DB-101	Distribution Box	ABS Plastic, medium impact	1
2	DB-102	Lid	ABS Plastic, high impact	1
3	DB-103	Seal	Monprene	1
4	DB-104	Distribution PCB	(None)	1
5	DB-105	Grommit	Monprene	10
6	M3 - 5.8	Insert	Brass, yellow brass	4
7	M3 - 6	Screw CH	Stainless steel	4
8	M5 - 10	Screw CH	Stainless steel	4
9	M5 - 9.5	Insert	Brass, yellow brass	4

DISTRIBUTION BOX

	NAME	DATE	AGRIGEL		
DRAWN	Dan	12/09/09			
APPROVED			TITLE Distribution Box		
MATERIAL					
TREATMENT			SIZE A4	DWG NO DB-100	REV
UNLESS OTHERWISE SPECIFIED DIMENSIONS ARE IN MILLIMETERS			FILE NAME: Distribution Box.dft		
1st ANGLE 2 PL ±0.02 3 PL ±0.005			SCALE:	WEIGHT:	SHEET 2 OF 6

REVISION HISTORY			
REV	DESCRIPTION	DATE	APPROVED

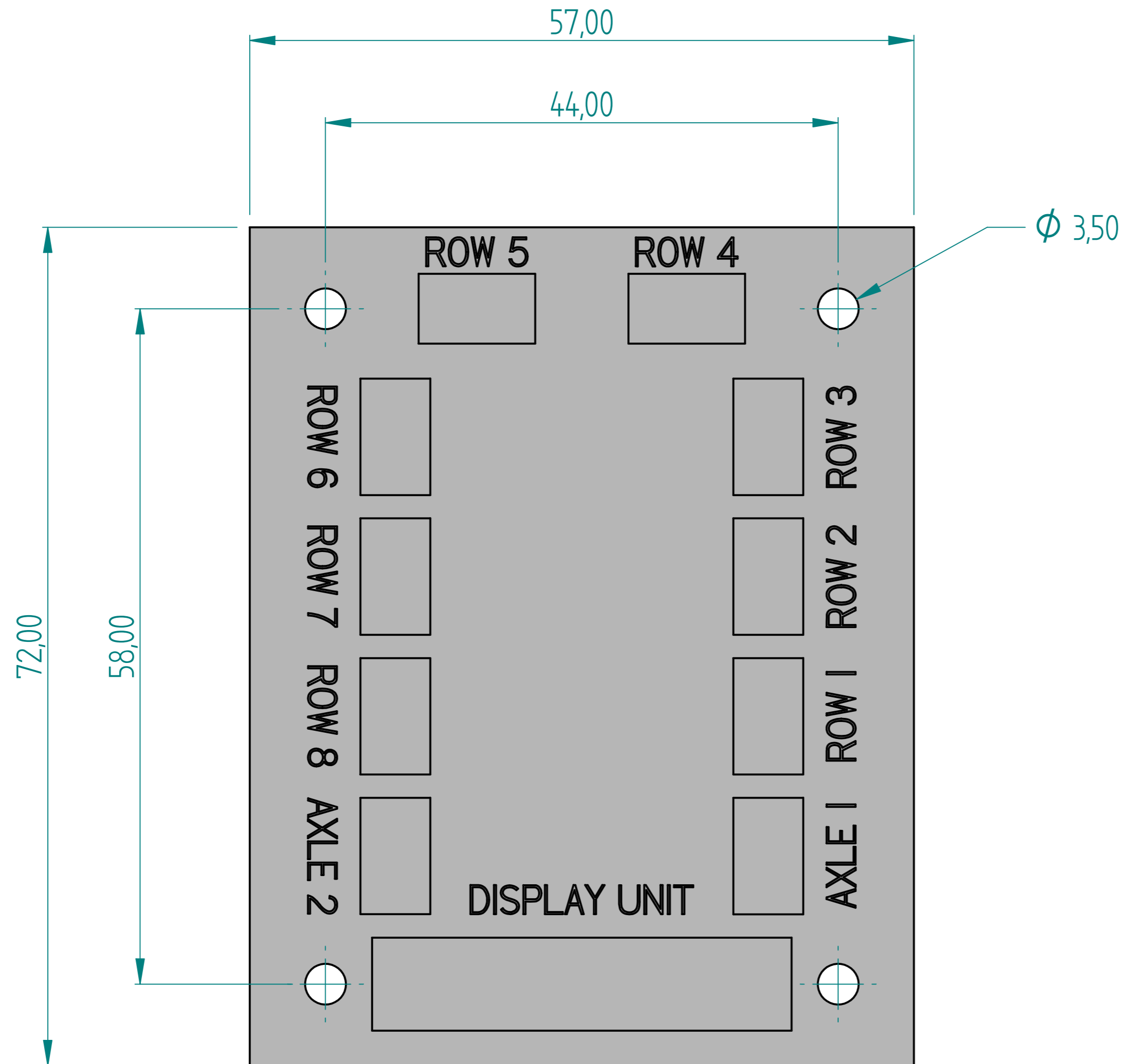

DISTRIBUTION BOX PCB

	NAME	DATE	AGRIGEL	
DRAWN	Dan	12/09/09	TITLE	
APPROVED			Distribution Box	
MATERIAL			SIZE	DWG NO
TREATMENT			A4	DB-100
UNLESS OTHERWISE SPECIFIED DIMENSIONS ARE IN MILLIMETERS			FILE NAME: Distribution Box.dft	REV
1 st ANGLE 2 PL ±0.02 3 PL ±0.005			SCALE:	WEIGHT:
			SHEET 3 OF 6	

REVISION HISTORY			
REV	DESCRIPTION	DATE	APPROVED

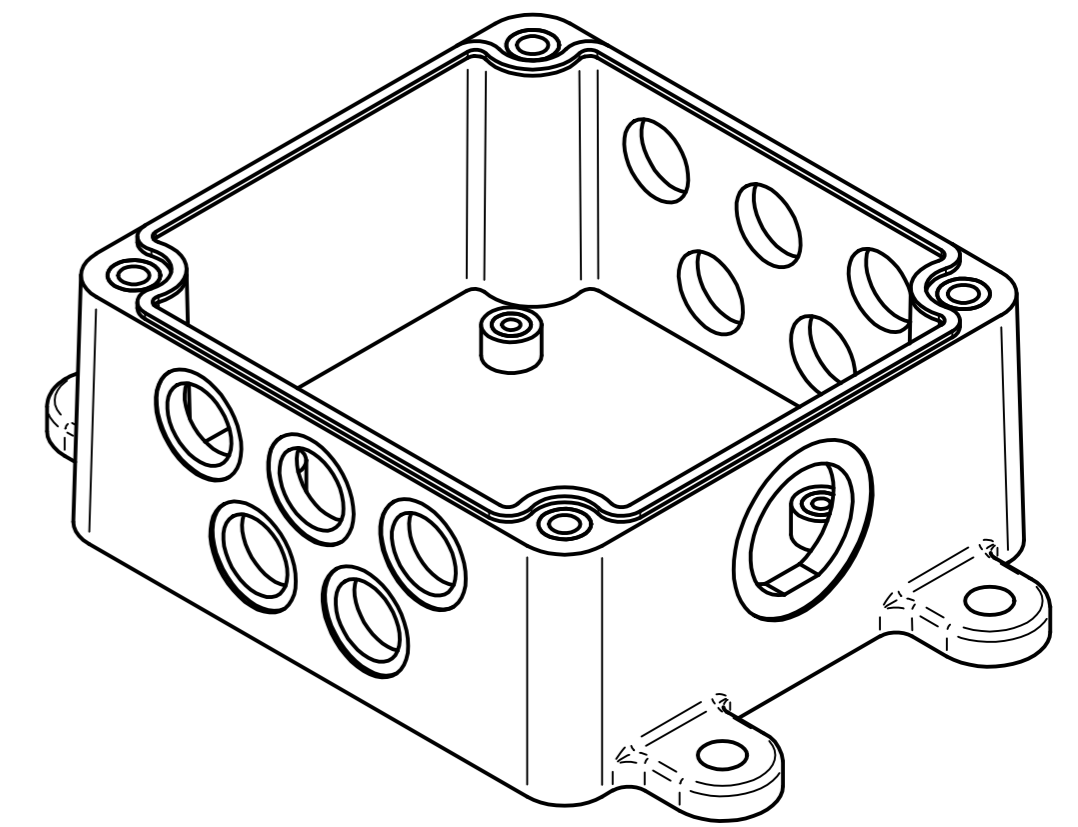
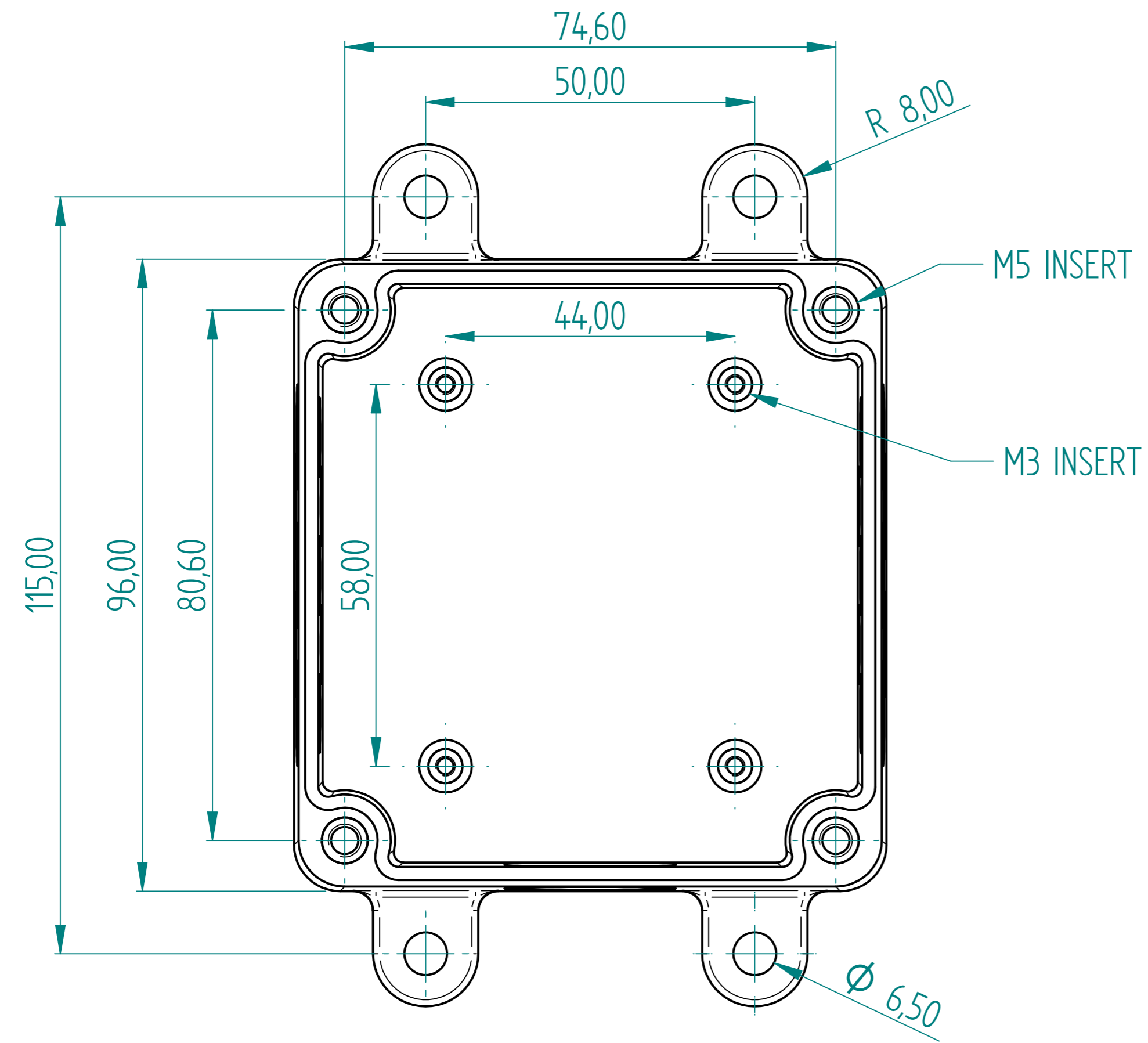
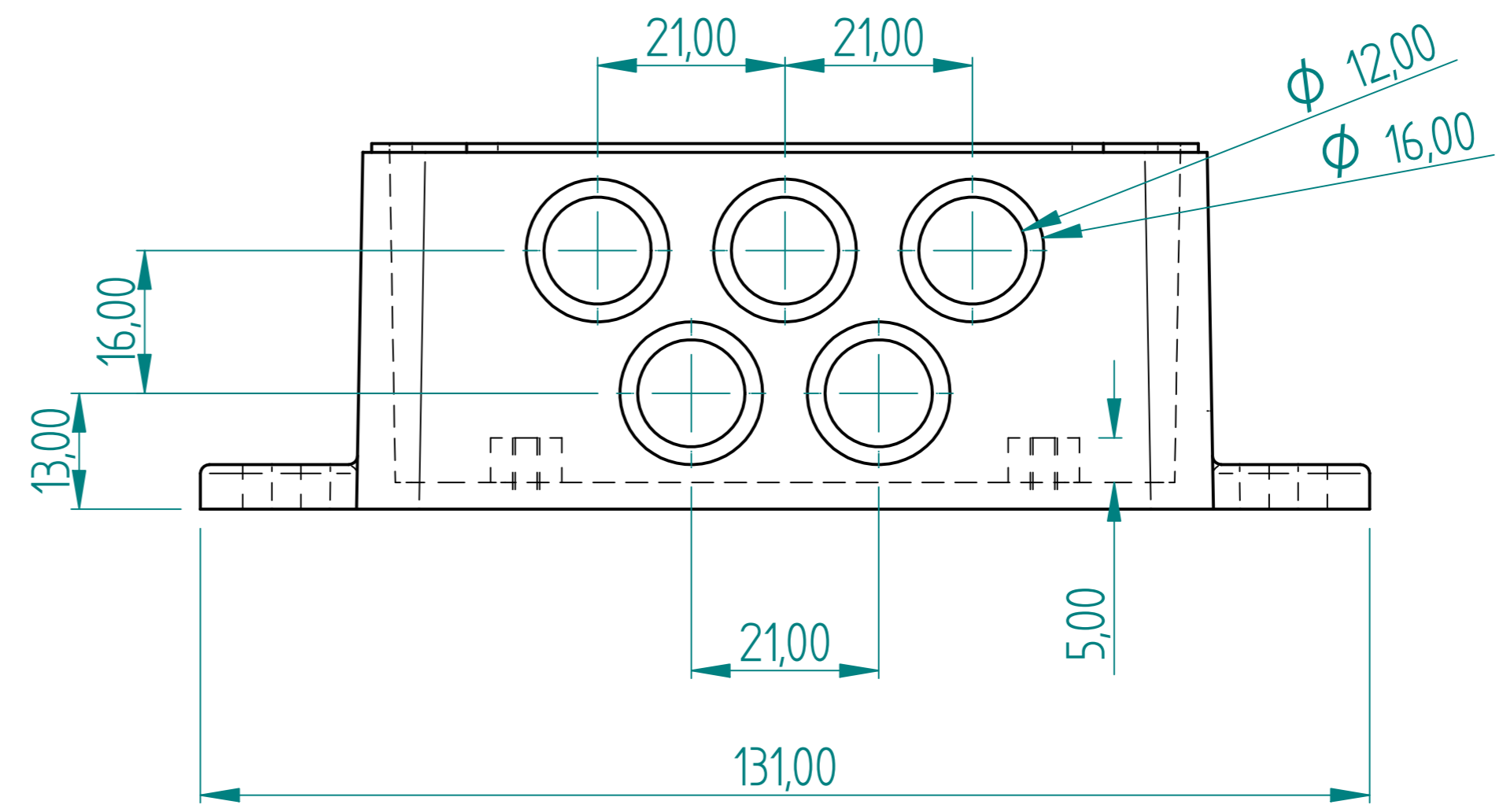
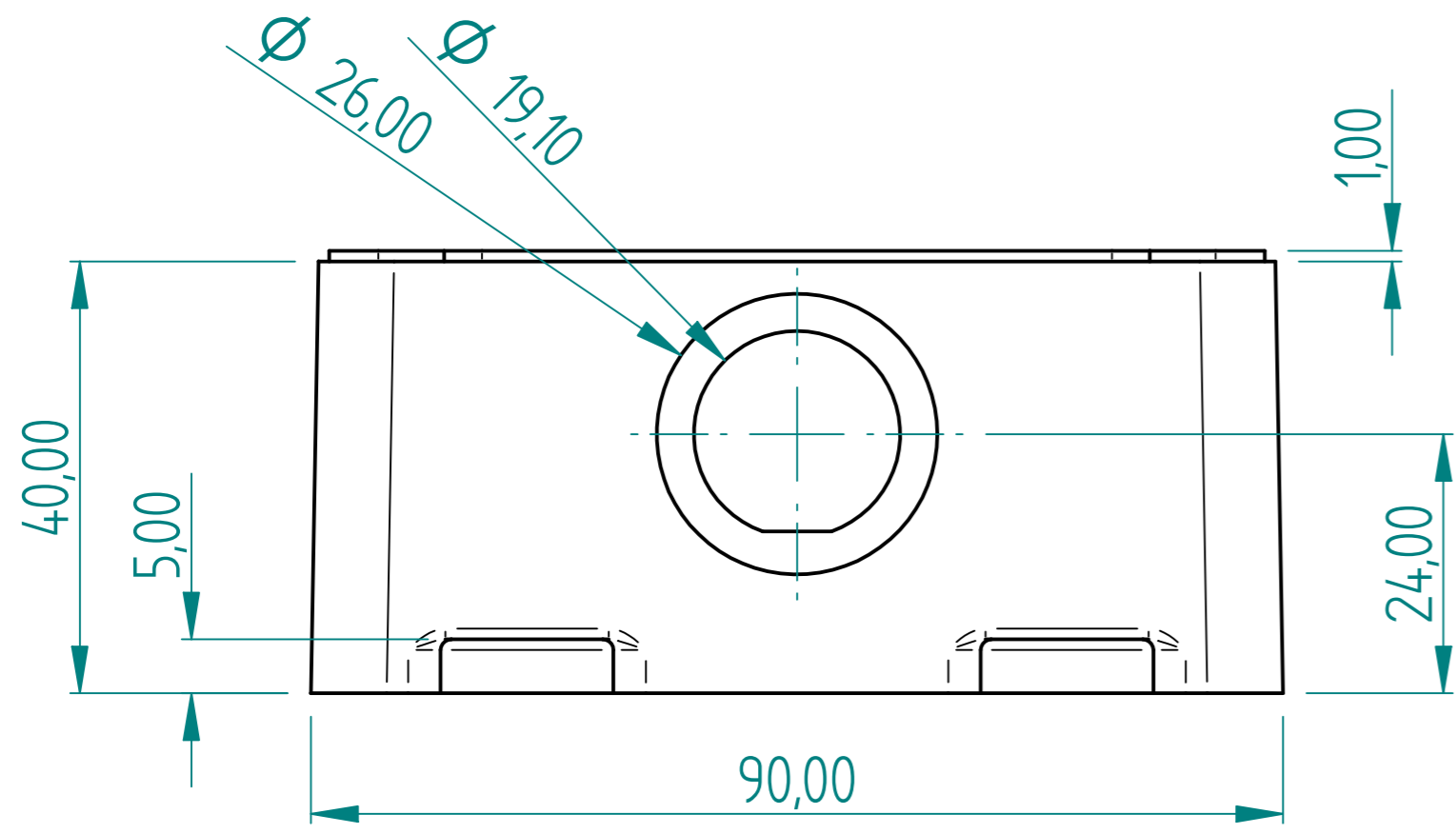

BOX

DRAWN	NAME	DATE	AGRIGEL	
APPROVED	Dan	12/09/09	TITLE	
MATERIAL			Distribution Box	
TREATMENT			SIZE	DWG NO
UNLESS OTHERWISE SPECIFIED DIMENSIONS ARE IN MILLIMETERS ANGLES $\pm 0,1^\circ$			A4	DB-100
			FILE NAME: Distribution Box.dft	REV
1st ANGLE 2 PL $\pm 0,02$ 3 PL $\pm 0,005$			SCALE:	WEIGHT:
			SHEET 4 OF 6	

REVISION HISTORY			
REV	DESCRIPTION	DATE	APPROVED

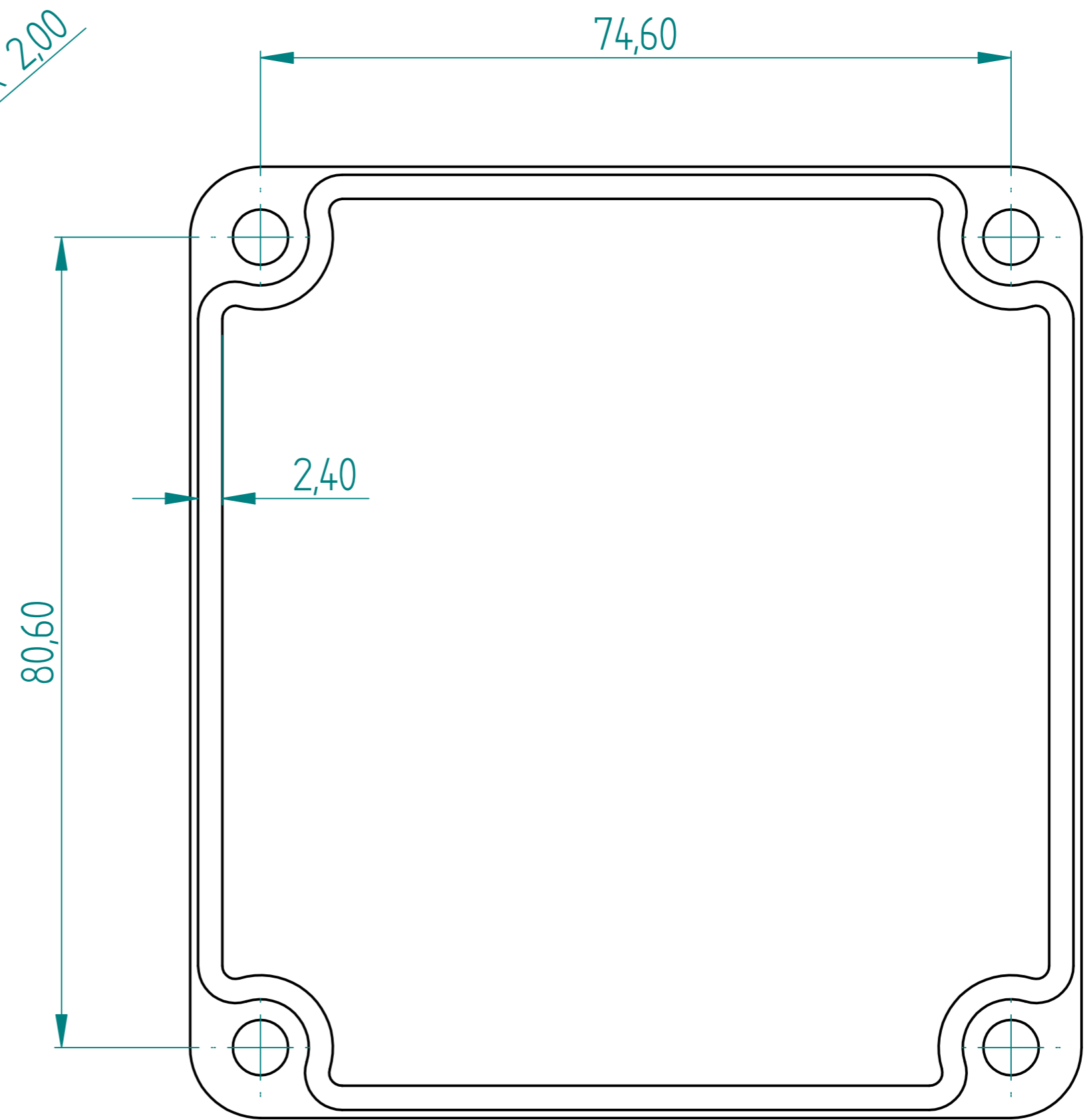
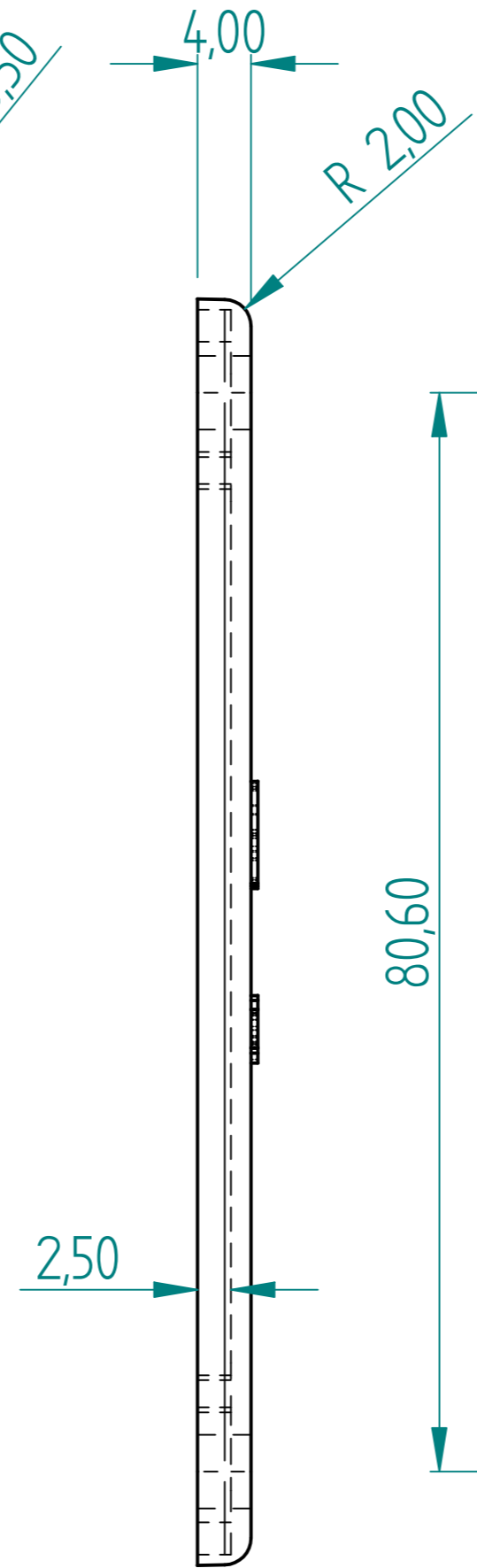
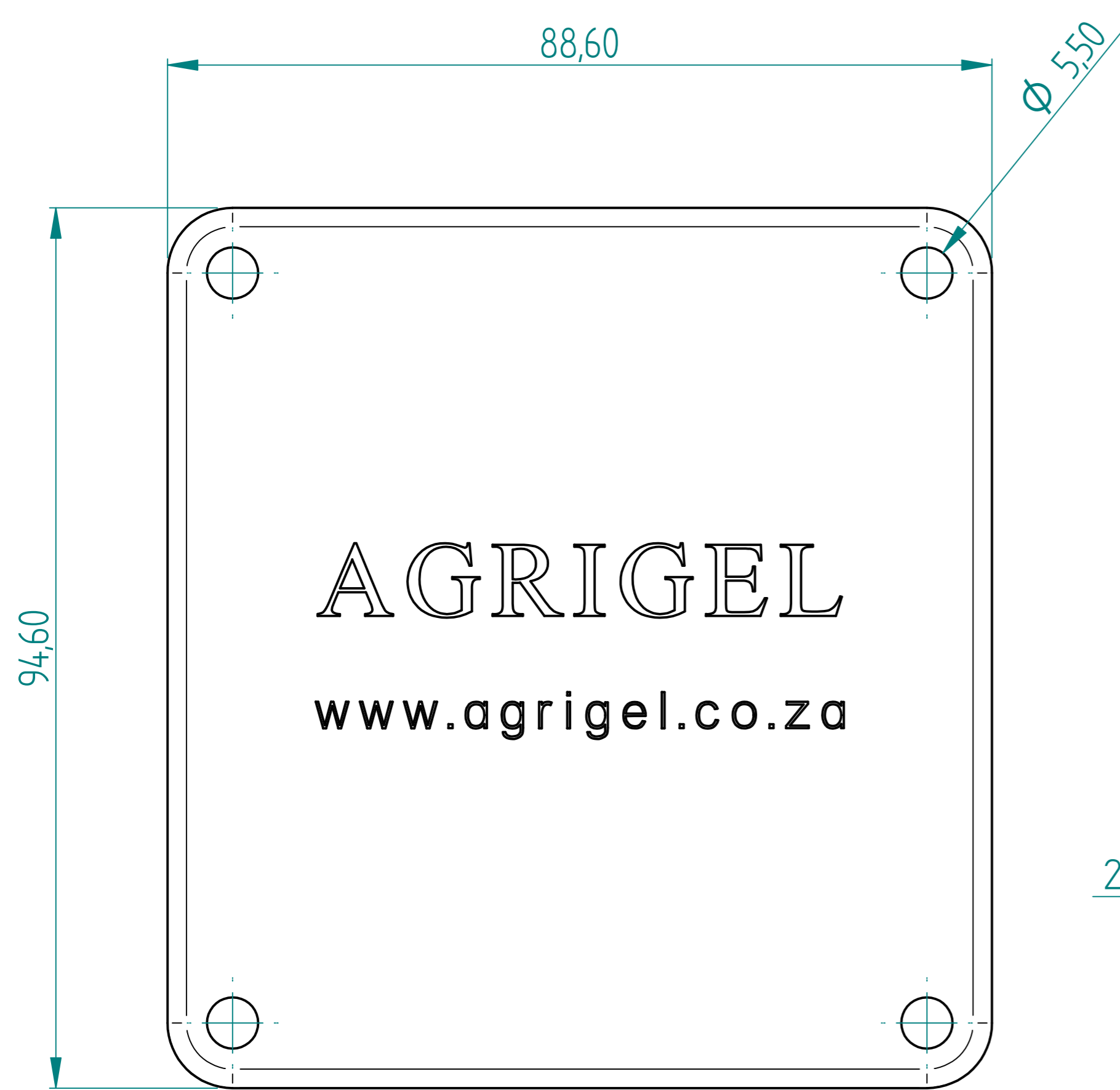

LID



DRAWN	NAME	DATE	AGRIGEL	
APPROVED	Dan	12/09/09	TITLE	
MATERIAL			Distribution Box	
TREATMENT			SIZE	DWG NO
UNLESS OTHERWISE SPECIFIED DIMENSIONS ARE IN MILLIMETERS ANGLES $\pm 0,1^\circ$			A4	DB-100
			FILE NAME: Distribution Box.dft	
1 st ANGLE			SCALE:	WEIGHT:
2 PL $\pm 0,02$ 3 PL $\pm 0,005$			SHEET 5 OF 6	

REVISION HISTORY			
REV	DESCRIPTION	DATE	APPROVED

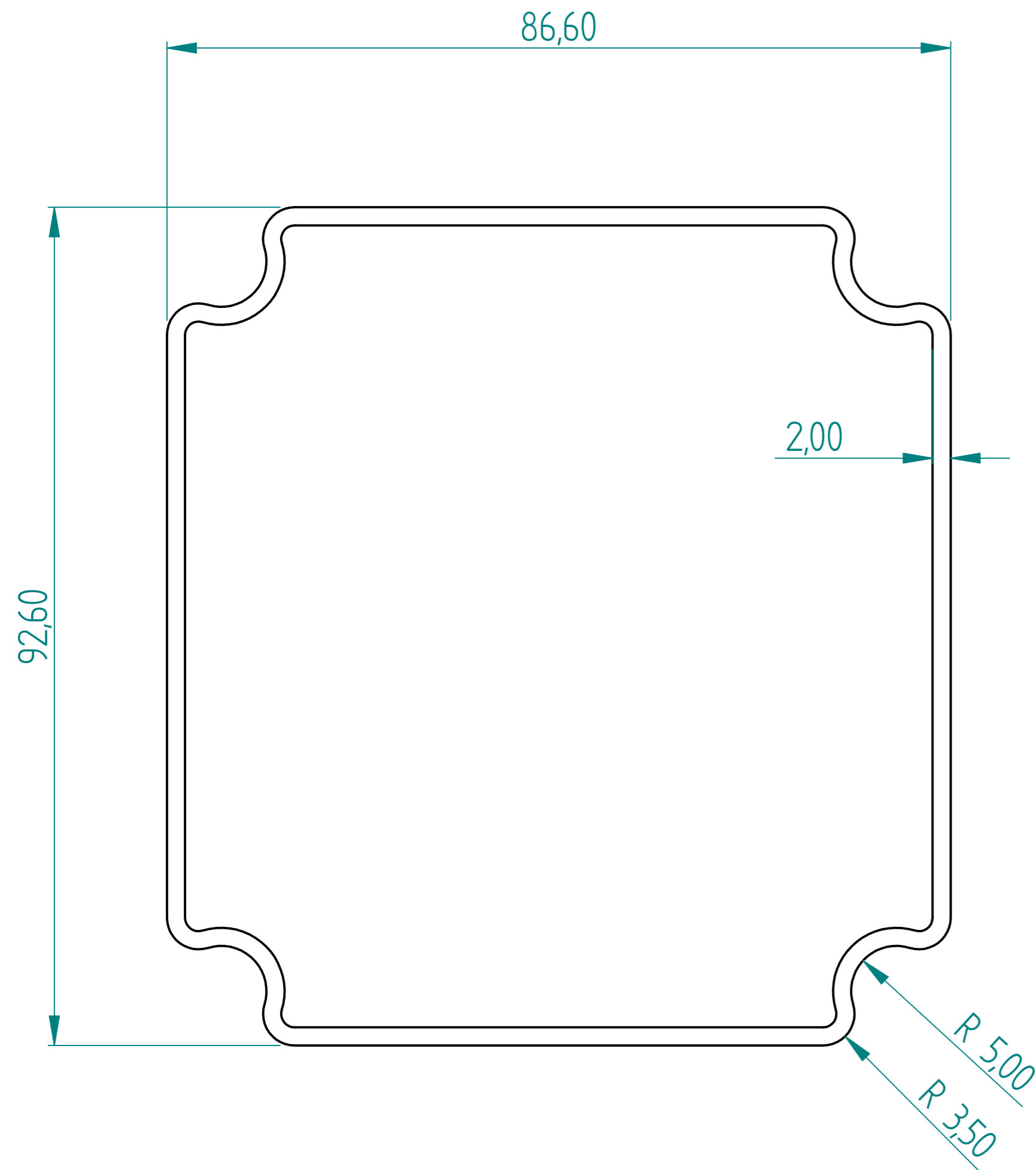

SEAL

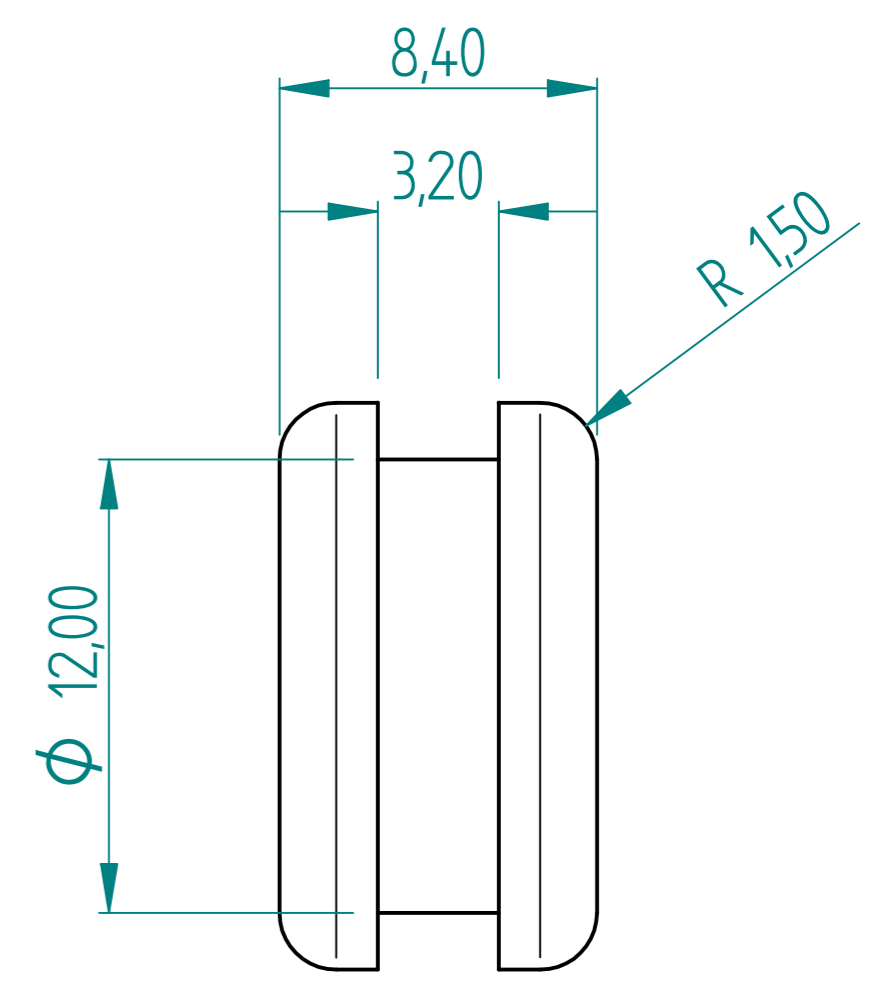
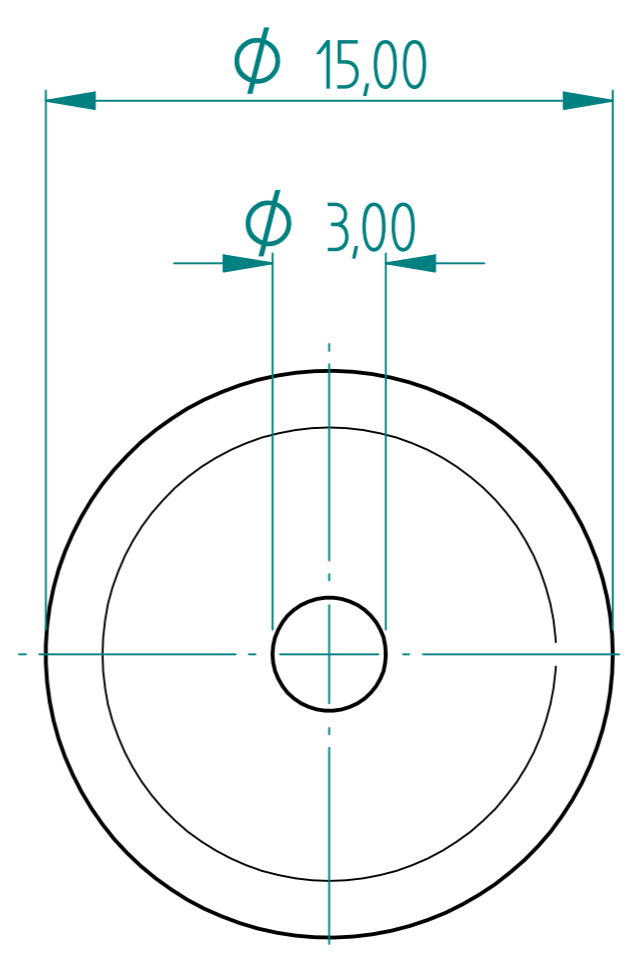
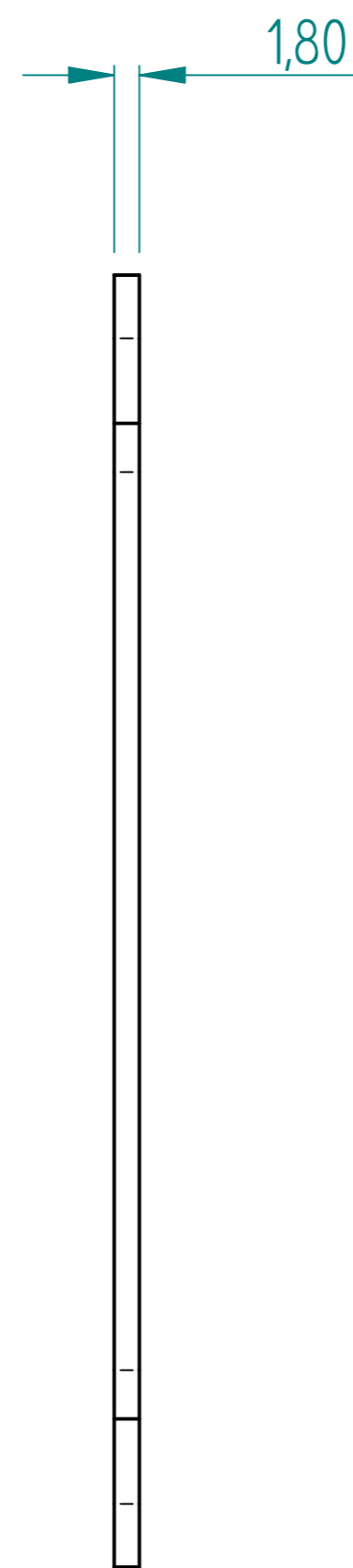

GROMMIT

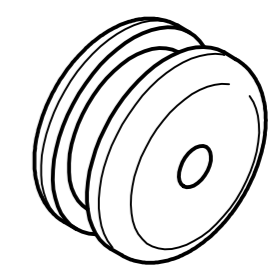

	NAME	DATE	AGRIGEL		
DRAWN	Dan	12/09/09			
APPROVED			TITLE Distribution Box		
MATERIAL					
TREATMENT			SIZE A4	DWG NO DB-100	REV
UNLESS OTHERWISE SPECIFIED DIMENSIONS ARE IN MILLIMETERS			FILE NAME: Distribution Box.dft		
1 st ANGLE ANGLES $\pm 0,1^\circ$			SCALE:	WEIGHT:	SHEET 6 OF 6
2 PL $\pm 0,02$ 3 PL $\pm 0,005$					