

REVISION HISTORY			
REV	DESCRIPTION	DATE	APPROVED

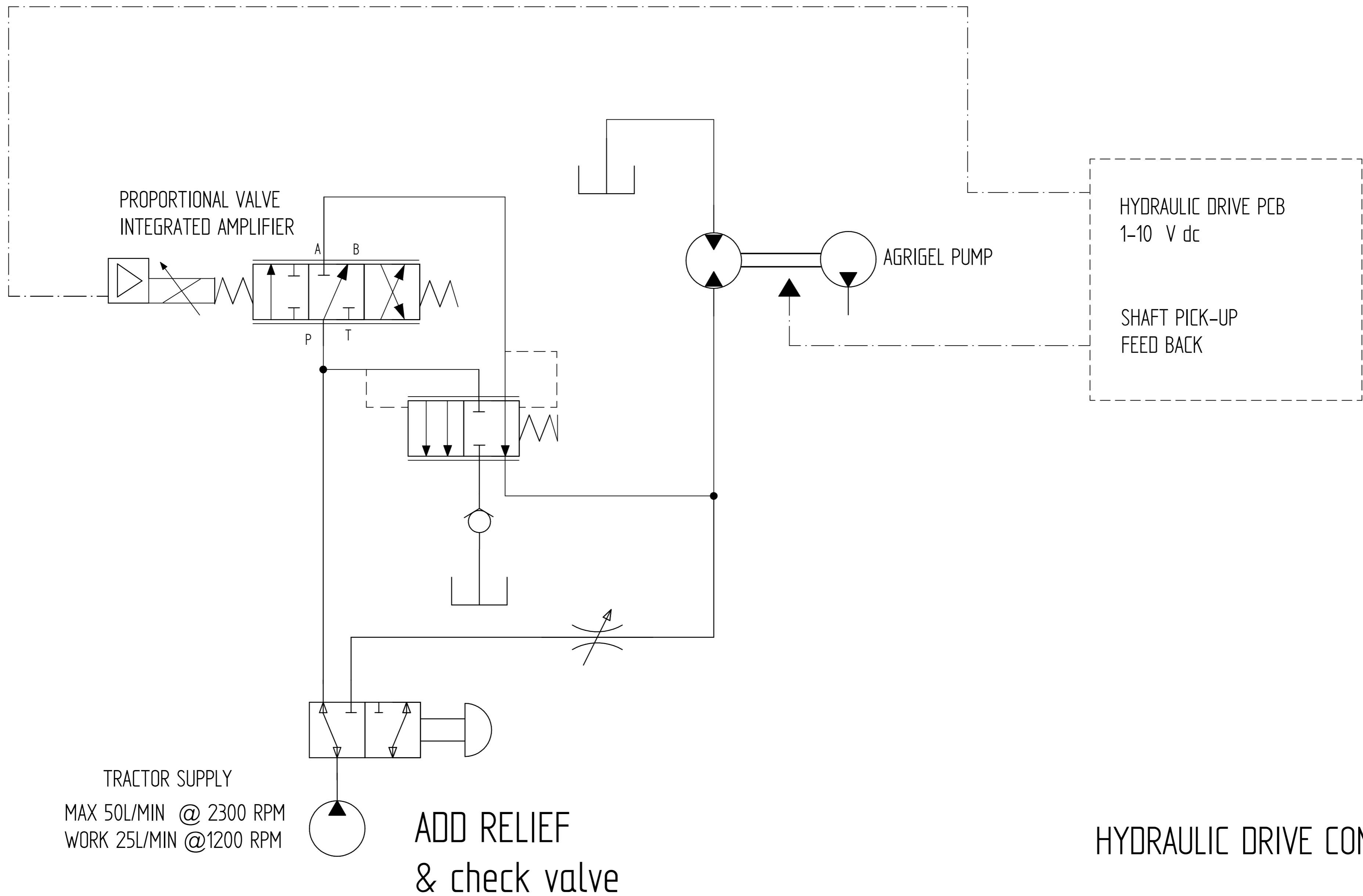

TRACTOR SUPPLY  
 MAX 50L/MIN @ 2300 RPM  
 WORK 25L/MIN @ 1200 RPM

ADD RELIEF  
 & check valve

# HYDRAULIC DRIVE CONTROL

	NAME	DATE	<b>AGRIGEL</b>	
DRAWN	DG	10/31/17		
APPROVED				
MATERIAL			TITLE	
TREATMENT			Hydraulic Drive Control	
UNLESS OTHERWISE SPECIFIED DIMENSIONS ARE IN MILLIMETERS			SIZE A4	DWG NO
ANGLES ±0.1°				REV
1st ANGLE 2 PL ±0.02 3 PL ±0.005			FILE NAME: Hydraulic Drive Control.dft	
SCALE:		WEIGHT:	SHEET 1 OF 2	