

REVISION HISTORY			
REV	DESCRIPTION	DATE	APPROVED

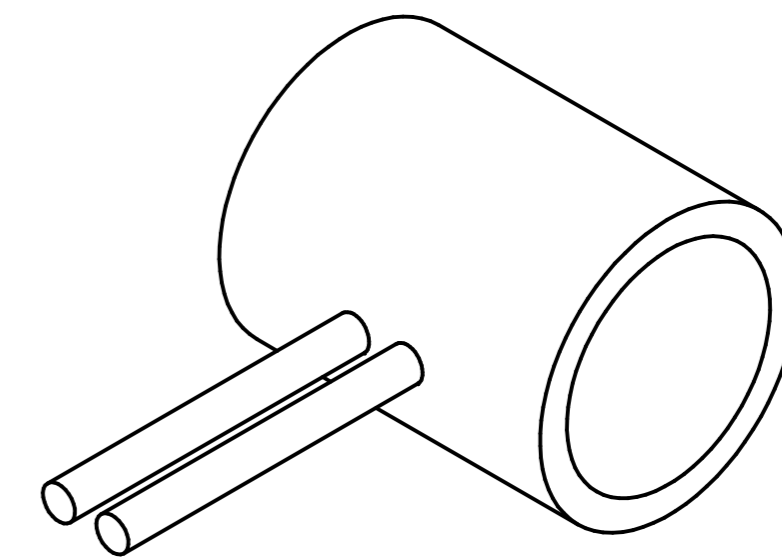
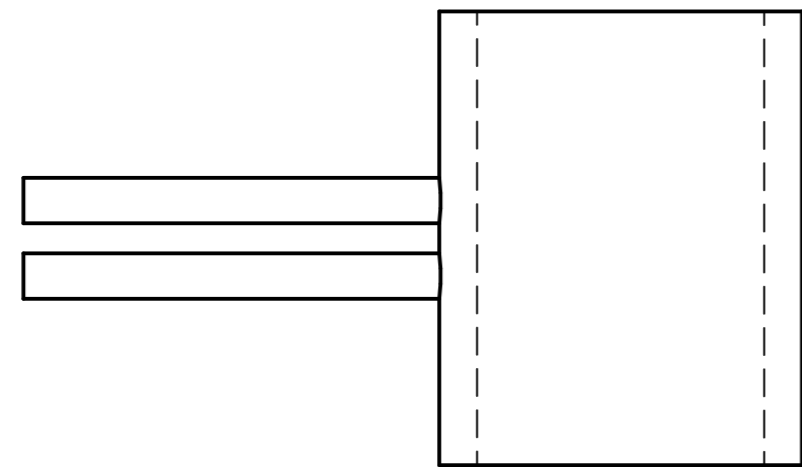
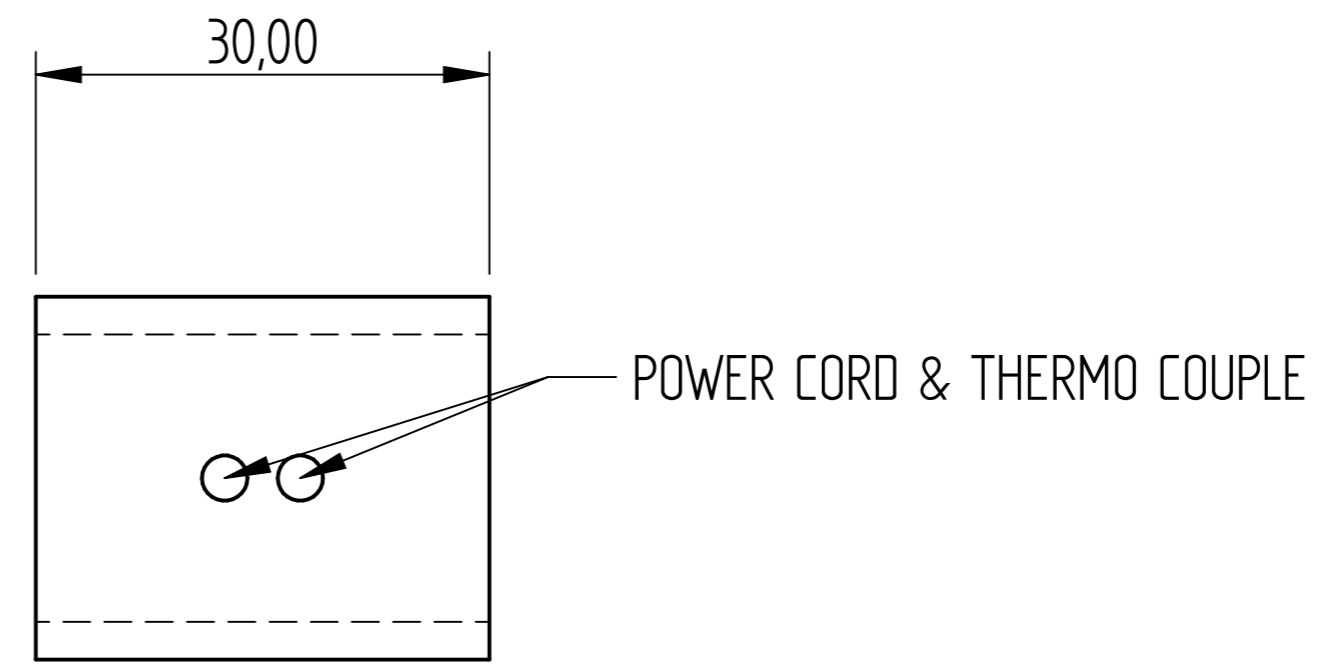
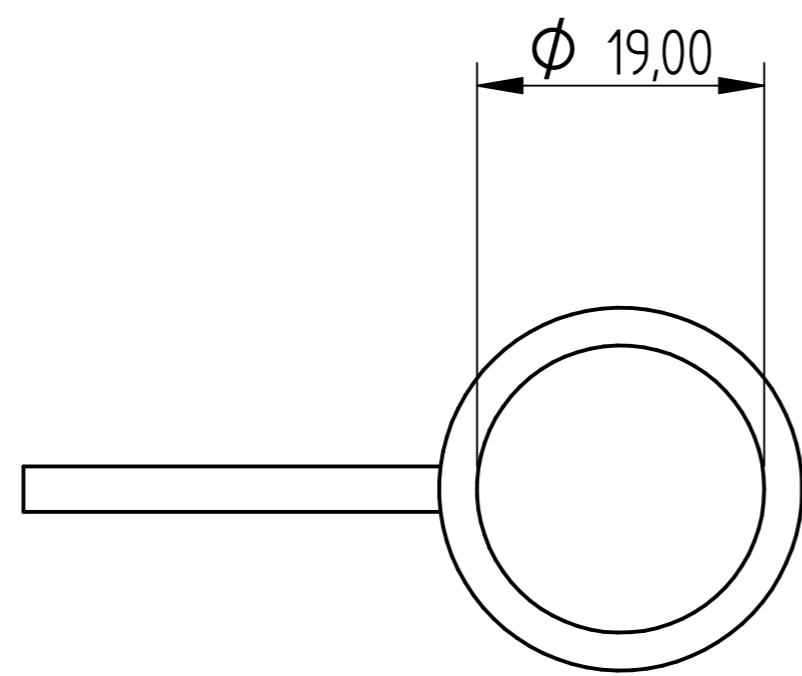

SUPER COIL

	NAME	DATE	AGRIGEL		
DRAWN	DG	09/26/16			
APPROVED					
MATERIAL					
TREATMENT			TITLE		
			Hub Box Lid Mould		
UNLESS OTHERWISE SPECIFIED DIMENSIONS ARE IN MILLIMETERS			SIZE A4	DWG NO	REV
1 st ANGLE 			FILE NAME: Hub Box Lid Mould.dft		
2 PL ±0.02 3 PL ±0.005			SCALE:	WEIGHT:	SHEET 4 OF 4