

REVISION HISTORY			
REV	DESCRIPTION	DATE	APPROVED

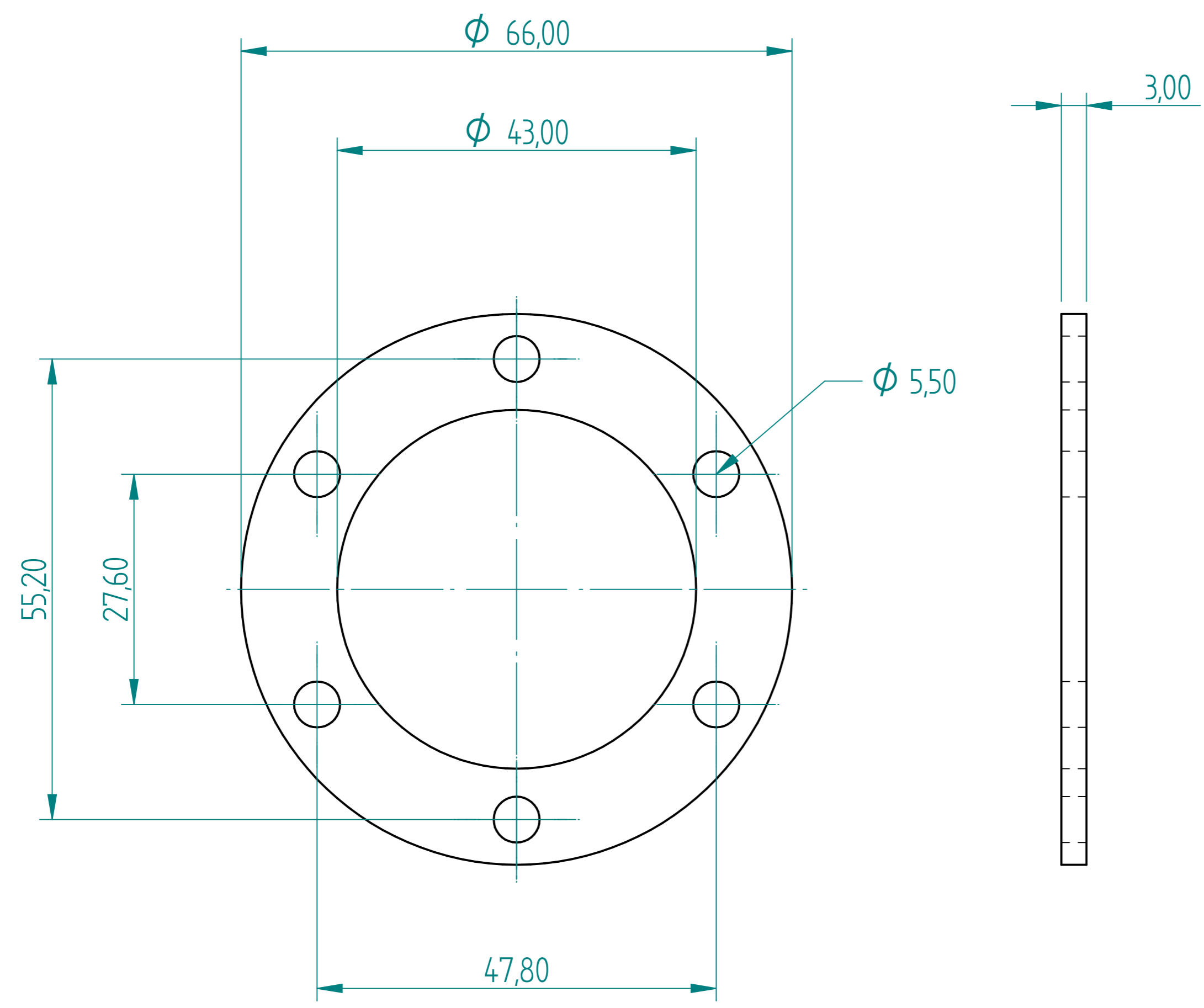

FLOW METER CLAMPING PLATE

	NAME	DATE	<b>AGRIGEL</b>		
DRAWN	Dan	10/11/24			
APPROVED			TITLE		
MATERIAL					
TREATMENT			UNLESS OTHERWISE SPECIFIED DIMENSIONS ARE IN MILLIMETERS ANGLES $\pm 0,1^\circ$		
			SIZE A4	DWG NO	REV
			FILE NAME: Flow Meter Clamping Plate.dft		
			SCALE:	WEIGHT:	SHEET 1 OF 2

