

SECTION A-A

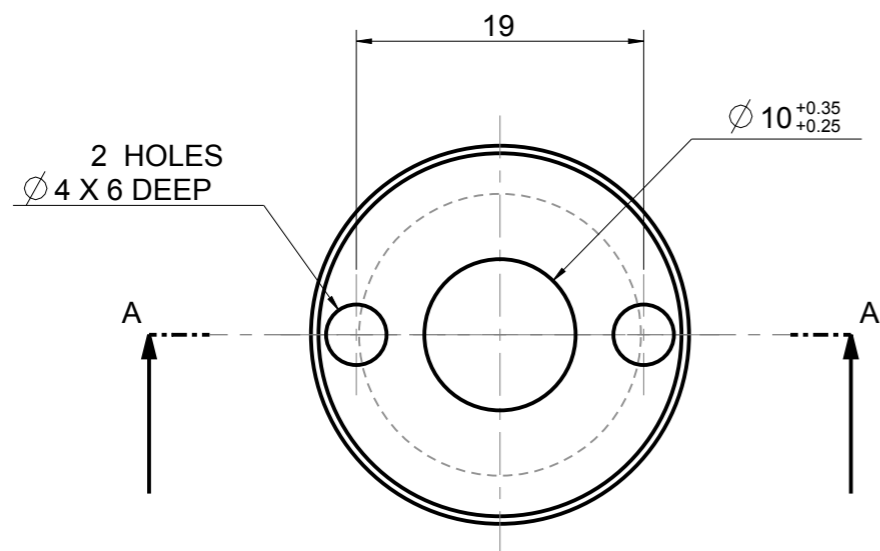

SCALE 2:1

NOTE:

R 1/2 DESIGNATES 1/2" BRITISH PARALLEL PIPE THREAD, BSPP. DIMENSIONS ARE AS FOLLOWS:

MAJOR DIAMETER: 20.955
 PITCH DIAMETER: 19.793
 MINOR DIAMETER: 18.631
 THREADS PER INCH: 14.

DYNAMIC FLUID CONTROL
 VALID FROM
 Nov-20-12
 UNTIL FURTHER NOTICE
 SIGN: *D. Galde*

© Copyright D.F.C.

A3		Pro/E	
PINCH VALVE		In Work	
MACHINING SYMBOLS TO ISO STANDARDS			
CASTING TOLERANCES UNLESS OTHERWISE SPECIFIED mm UNITS		MACHINING TOLERANCES UNLESS OTHERWISE SPECIFIED mm UNITS	
UP TO 75	± 1.0	UP TO 120	± 0.3
OVER 75 UP TO 150	± 1.5	OVER 120 UP TO 300	± 0.5
OVER 150 UP TO 250	± 2.0	OVER 300 UP TO 1000	± 0.8
OVER 250 UP TO 500	± 3.0	OVER 1000	± 1.2
OVER 500	± 4.0	ANGLES	± 0.1
ANGLES	± 1.0	DRILLED HOLES	± 0.1

1	0	25 DIA ROUND POM BLACK	ZMR025000PPOM	POLYACETAL
ITEM	QTY	DESCRIPTION	PART CODE	MATERIAL
REV. A	DATE: 20-Aug-12 01:32:05 PM	DONE BY:		
AVENG MANUFACTURING DFC		32 Lincoln Road, Benoni South P.O. BOX 5064, Benoni South, 1502, Gauteng, South Africa Tel: +27 11 748 0200 Fax: +27 11 421 2749		1 ST. ANGLE
THIS DRAWING AND DESIGN IS THE PROPERTY OF DYNAMIC FLUID CONTROL AND MUST NOT BE COPIED OR DISCLOSED TO ANY THIRD PARTY WITHOUT THE CONSENT OF THE COMPANY IN WRITING AND TO BE RETURNED UPON REQUEST.		SCALE: NTS	NAME	DATE
DRAWN		Calldo, Dennis	20-Jul-12 10:56:00 AM	
CHECKED		Calldo, Dennis	20-Aug-12 01:32:05 PM	
TITLE: G 1/2 X 10 PULL BAR BUSH			DRAWING No: / MODLE No: BEOH010CMBPPOM	
SHEET 1 OF 1				