

REVISION HISTORY			
REV	DESCRIPTION	DATE	APPROVED

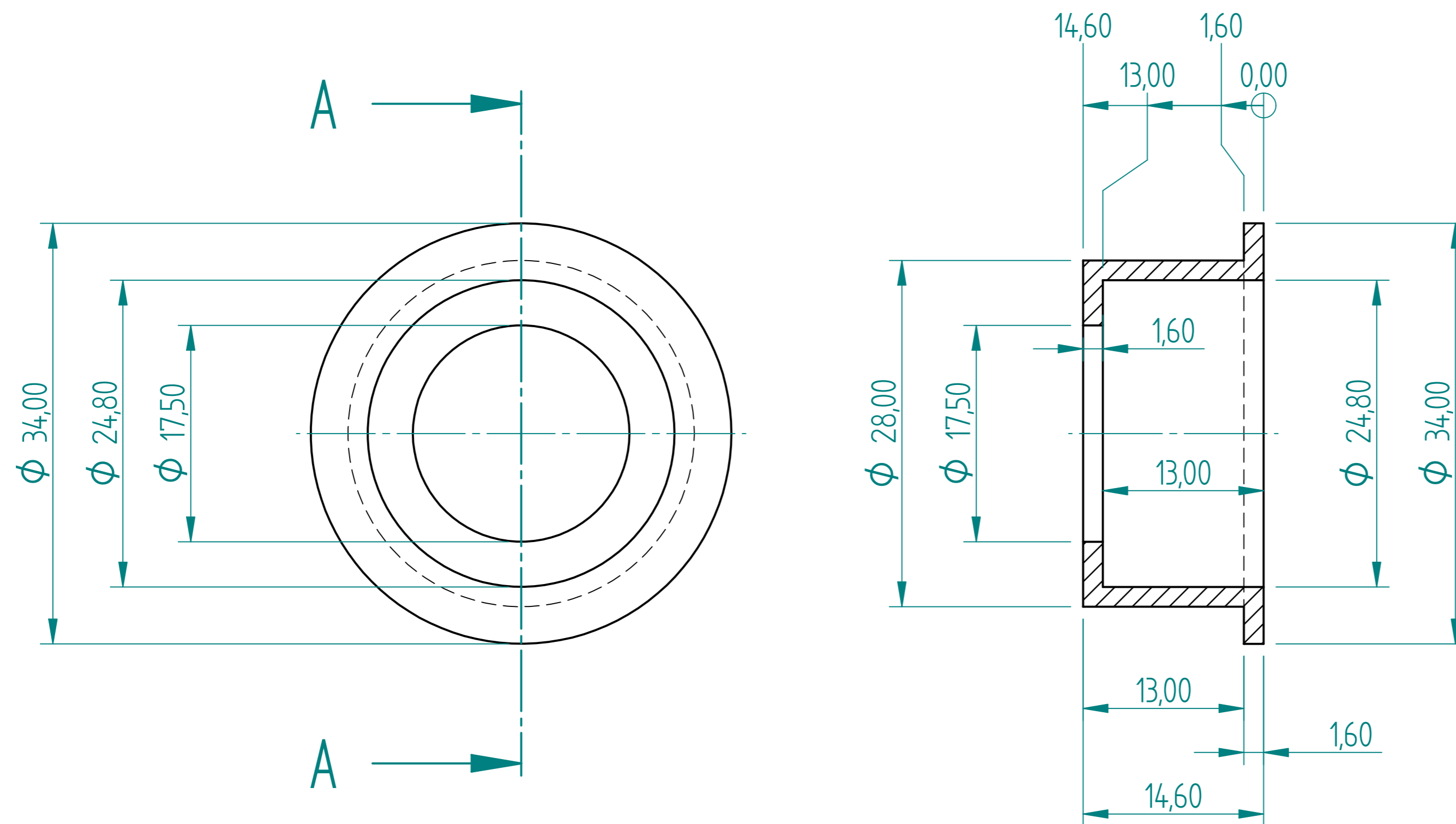

SECTION A-A

V150 STD SPRING CUP

	NAME	DATE	PREMAC	
DRAWN	Dan	06/01/10	PRECISION MACHINE MANUFACTURERS (PTY)LTD.	
APPROVED			TITLE	
MATERIAL			V150 Std Spring Cup	
TREATMENT			SIZE	DWG NO
UNLESS OTHERWISE SPECIFIED DIMENSIONS ARE IN MILLIMETERS ANGLES ±0.1° 1st ANGLE			A2	REV
			FILE NAME: Std Spring Cup.dft	
2 PL ±0.02 3 PL ±0.005			SCALE:	WEIGHT: SHEET 1 OF 1